

Study for the analysis of impacts from RoHS2 on non-road mobile machinery without an on-board power source, on windows and doors with electric functions, and on the refurbishment of medical devices

Report for the European Commission DG Environment under Framework Contract N° ENV.C.2/FRA/2011/0020, Specific Contract No ENV/2014/SI2.687871/ETU/A2

Final Report

Authors:

Carl-Otto Gensch, Oeko-Institut

Yifaat Baron, Oeko-Institut

Katja Moch, Oeko-Institut

12/03/2015

Report for:

The European Commission

Prepared by:

Oeko-Institut e.V.

Freiburg Head Office
P.O. Box 1771
79017 Freiburg, Germany
Street Address
Merzhauser Str. 173
79100 Freiburg, Germany
Tel. +49 (0) 761 – 4 52 95-0
Fax +49 (0) 761 – 4 52 95-288

Web: www.oeko.de

Peer reviewed and approved by:

Adrian Gibbs (Eunomia Research & Consulting Ltd.)
.....

Contact Details

Eunomia Research & Consulting Ltd

37 Queen Square
Bristol
BS1 4QS
United Kingdom
Tel: +44 (0)117 9172250
Fax: +44 (0)8717 142942
Web: www.eunomia.co.uk

Acknowledgements

We would like to express our gratitude towards stakeholders who have taken an active role in the contribution of information concerning the requests for exemption handled in the course of this project.

Disclaimer

Eunomia Research & Consulting and Oeko-Institut have taken due care in the preparation of this report to ensure that all facts and analysis presented are as accurate as possible within the scope of the project. However no guarantee is provided in respect of the information presented, and Eunomia Research & Consulting and Oeko-Institut are not responsible for decisions or actions taken on the basis of the content of this report.

Contents

| | |
|---|-----------|
| List of Tables | iii |
| List of Figures | iii |
| 1.0 Background and objective | 1 |
| 1.1 Policy context..... | 1 |
| 1.2 Objectives | 4 |
| 2.0 Non-Road Mobile Machinery in the Context of RoHS | 5 |
| 2.1 Abbreviations..... | 5 |
| 2.2 Introduction | 5 |
| 2.3 Legal Background | 6 |
| 2.4 Product Group Description and Background | 8 |
| 2.4.1 <i>Problem Definition</i> | 9 |
| 2.4.2 <i>NRMM with and without an On-Board Power Source</i> | 10 |
| 2.4.3 <i>Mobilised Machinery Operated at Fixed Locations</i> | 17 |
| 2.5 Applicability of the RoHS Article 2(4) Exclusions | 22 |
| 2.6 Critical Review | 23 |
| 2.6.1 <i>Difficulty of Compliance</i> | 23 |
| 2.6.2 <i>Impact Review of the Various Product Groups</i> | 25 |
| 2.6.3 <i>Conclusions and Recommendations</i> | 33 |
| 2.7 References | 36 |
| 3.0 Windows and Doors with Electric Functions | 37 |
| 3.1 Abbreviations..... | 37 |
| 3.2 Introduction | 37 |
| 3.3 Background of Review | 38 |
| 3.4 Product Group Description and Background | 38 |
| 3.4.1 <i>Problem Definition</i> | 43 |
| 3.4.2 <i>Legislative Background of Windows and Doors</i> | 45 |
| 3.5 Compliance with RoHS | 47 |
| 3.5.1 <i>Burden of Documentation</i> | 47 |
| 3.5.2 <i>Potential of Components for Containing RoHS Substances</i> | 49 |
| 3.6 Critical Review | 53 |
| 3.6.1 <i>Difficulty of Compliance</i> | 53 |
| 3.6.2 <i>Policy Options</i> | 57 |
| 3.6.3 <i>Impact Indicators</i> | 57 |

| | | |
|--------------|--|------------|
| 3.6.4 | <i>Environmental Impacts</i> | 58 |
| 3.6.5 | <i>Economic Impacts</i> | 60 |
| 3.6.6 | <i>Social Impacts</i> | 63 |
| 3.7 | Summarised Comparison of Options..... | 65 |
| 3.8 | Summary and Recommendation | 66 |
| 3.9 | References | 68 |
| 4.0 | Refurbishment of Medical Devices in the Context of RoHS | 70 |
| 4.1 | Abbreviations..... | 70 |
| 4.2 | Procedural Issues..... | 70 |
| 4.3 | Problem Definition and Background..... | 72 |
| 4.4 | Background | 74 |
| 4.4.1 | <i>Legal Background</i> | 75 |
| 4.5 | Objectives | 80 |
| 4.6 | Policy Options | 81 |
| 4.7 | The Baseline..... | 81 |
| 4.7.1 | <i>RoHS Compliance</i> | 87 |
| 4.8 | Results from the Public Consultation | 91 |
| 4.9 | Analysis of Impacts | 91 |
| 4.9.1 | <i>Impact Indicators</i> | 92 |
| 4.9.2 | <i>Environmental Impacts</i> | 93 |
| 4.9.3 | <i>Economic Impacts</i> | 96 |
| 4.9.4 | <i>Social Impacts</i> | 98 |
| 4.10 | Summarised Comparison of Options..... | 100 |
| 4.11 | Recommendation | 102 |
| 4.12 | References | 104 |
| A.1.0 | Appendix 1: Summary of Stakeholder Contributions Related to the Review of Non-Road Mobile Machinery (NRMM) | 105 |
| A.2.0 | Appendix 2: Questionnaire Concerning Impacts on Refurbishment - Technical and Socio-economic Considerations Concerning Refurbishment Practices in the Context of RoHS | 108 |

List of Tables

| | |
|---|-----|
| Table 2-1: 2013 Diesel Gen-Set Market, Parkinson's data | 19 |
| Table 3-1: Window and Door Components Potentially Containing RoHS Substances | 49 |
| Table 3-2: RoHS substances and their corresponding provisions in other EU regulations and international agreements | 51 |
| Table 3-3: Categorization of Windows and Doors (W&D) with regards to the scope of RoHS..... | 54 |
| Table 3-4: Impact Indicators for the Product Group Windows and Doors (W&D) with Electric Function | 58 |
| Table 3-5: Comparison of Options..... | 65 |
| Table 4-1: GRP Refurbishment Practice Process Steps | 83 |
| Table 4-2: Weight of RoHS Restricted Substances Used in Category 8 Equipment, Including Data for Sub-categories Where Known | 88 |
| Table 4-3: Impact Indicators for the Refurbished Medical Devices and Parts | 92 |
| Table 4-4: Comparison of Options – Range of Impacts in Relation to Option 1 (Business as Usual) | 100 |
| Table 4-5: Summary of Stakeholder Contributions Related to the Review of NRMM | 105 |

List of Figures

| | |
|--|----|
| Figure 2-1: Pictures of identical machines with an on-board power source and cord connected for professional use..... | 11 |
| Figure 2-2: Number of Companies Versus their Annual Production of R&S Vehicles (Spain 2012 - 1000 manufacturers) | 15 |
| Figure 2-3: Tri-metal Bearing Illustration | 20 |
| Figure 3-1: Indication where the Electric Components are Located in the Windows and Doors (indicative list, from VFF 2013) | 40 |
| Figure 3-2: Production and Consumption of Windows and Doors across EU 27 in 2010 | 41 |
| Figure 3-3: Window and External Door Manufacturers in Germany - Size by Employees; Information provided by EuroWindow | 43 |
| Figure 4-1: Can a Refurbished Device be Placed on the EU Market? | 79 |
| Figure 4-2: Compliance of Spare Parts..... | 79 |
| Figure 4-3: Illustration: RoHS Substance Restrictions and the Possibilities of Placing a Product on the Market | 80 |

1.0 Background and objective

1.1 Policy context

The RoHS Directive (2002/95/EC) (RoHS 1) has been recast and has now become Directive 2011/65/EU that entered into force on 21 July 2011, repealing Directive 2002/95/EC on 3 January 2013. The RoHS Directive (2011/65/EU) on the restriction of the use of certain hazardous substances in electrical and electronic equipment requires “that EEE placed on the market, including cables and spare parts for its repair, its reuse, updating of its functionalities or upgrading of its capacity, does not contain the substances listed in Annex II” (i.e. lead, mercury, cadmium, hexavalent chromium, polybrominated biphenyls and polybrominated diphenyl ethers).

In 2008 the European Commission launched the recast of the RoHS 1 Directive 2002/95/EC. A recast proposal accompanied by an impact assessment was published in December 2008. This Commission proposal introduced a few new definitions and extended the original RoHS scope to medical devices and monitoring and control instruments. Substantial changes were made to this proposal by the Council and the Parliament before adoption on 8 June 2011 of Directive 2011/65/EU (RoHS 2)¹: This included among others the introduction of a product category "other EEE" (i.e. the introduction of an "open scope" making the Directive applicable to all EEE) and a broader interpretation of EEE as a result of a new definition of the dependency on electricity. These changes to the Commission recast proposal were not subject to the EU impact assessment procedure; nevertheless the RoHS 2 Directive 2011/65/EU (RoHS 2 Directive, hereafter referred to as RoHS 2), published in the OJ in July 2011, includes all these elements (see RoHS 2 Articles 2(1), 3(2) and Annex I category 11). These changes provide the initial outline for products considered to be “newly in scope”, aside from the products and devices falling under categories 8 and 9.

The RoHS 2 Directive, by its Article 2(4), provides a 10 entry list of specific equipment, which is excluded from the scope, e.g. aerospace and military equipment, means of transport, large-scale fixed installations, and photovoltaic panels. These are, at the moment, the only EEE that do not fall under the scope of the new Directive.

Also introduced by the Council and the Parliament, RoHS 2 foresees a transitional arrangement until 22 July 2019 for electrical and electronic equipment that was formerly outside the scope of RoHS 1 but that is now in scope (see Article 2(2)). The transition period does not change the legal status of these products as non-compliant. It only means that products newly in scope may still be placed and circulated on the EU market until 22 July 2019, even if they do not comply.

Pursuant to Article 24(1) of the Directive, no later than 22 July 2014, the Commission was to examine the need to amend the scope of the Directive and to present a report

¹ The Directive legal text is available under:
<http://eur-lex.europa.eu/LexUriServ/LexUriServ.do?uri=CELEX:32011L0065:EN:NOT>

thereon to the European Parliament and the Council, accompanied by a legislative proposal, if appropriate, with respect to any additional exclusions related to that EEE.

The Commission made two declarations on this point, stating that no scope changes to the Directive should be adopted without a prior impact assessment and that the review of the scope should not be limited to adding exclusions, but could cover the entire scope.

To this end, several unassessed scope related changes were analysed in two Commission studies between 2011 and 2014. The results of these studies, have led to discussions concerning the possible addition of exclusions for electric bicycles and pipe-organs in Article 2(4), as well as concerning possible amendments to the wording of Articles 2(2), 4(3) and 4(4). These changes were understood to conclude the possible changes of the Directive to be reviewed in the context of the Article 24(1) provision. However, recently stakeholders notified the Commission of some additional problems, which have been identified, that should be analysed in depth in this respect, concerning:

- **Non-road mobile machinery** is excluded from the scope via Article 2(4)(g). The definition of non-road mobile machinery in Article 3(28) requires an on-board power source. According to industry, the same type of equipment is however available with and without an on-board power source (e.g. professional floor cleaning machines). The identical EEE with external power source (cable) is currently in scope despite the similarities of such devices to models that are not in scope. Stakeholders have raised concern that compliance in such cases may result in significant costs.
- **Windows and doors with electric functions** fall to some extent within the scope of RoHS 2 (cf. RoHS 2 FAQs) under category 11 and will have to comply with the substance restrictions from 22 July 2019. As industry has not been involved actively until recently with the compliance requirements for this sector, this product group was only partly assessed in the 2011 BIOIS study prepared for the Commission. Here too, stakeholders have raised concern that compliance in such cases may result in significant costs.
- The significance of **refurbishment operations** in the EEE sector has been gaining in importance in recent years. This is partly tied with the coming into scope of medical devices (Cat. 8) and of monitoring and control instruments (Cat. 9) as well as other EEE newly in scope, which have longer service lives and are thus designed to be more robust. For such equipment, some manufacturers have developed refurbishment practices in which parts are recovered from faulty equipment, refurbished and used for the repair of similar devices. Where this practice is implemented, it is said that reuse can avoid recycling and disposal of valuable resources, decreasing the demand for manufacture of new devices and parts, as well as the consumption of materials and energy tied to it. According to new stakeholder input, besides the savings tied to resources, this practice also provides an alternative for supplying certain devices at more affordable prices. In the medical industry, this means that certain devices can be obtained as refurbished models at lower costs. This results in more flexibility in the allocation of limited budgets towards other acquisitions that would otherwise be delayed. However, in many

cases as devices are intended for professional use they are not manufactured in quantities comparable to those relevant for consumer products. In this sense, some manufacturers shall have a single manufacturing facility worldwide, as well as a single facility for refurbishment operations of parts to be used in the repair of devices used and resold worldwide. Before such products came into the scope of RoHS, old ("non-compliant") products from outside Europe that had not been placed on the EU market, could enter refurbishment facilities, and could thus later be resold on the EU market, regardless of possible RoHS substance content. Stakeholders have raised concern that restriction of such activities could result in a decrease of demand in the EU for such refurbished equipment in light of legal requirements. This in turn could cause more parts and devices to be reverted from reuse operations to recycling and disposal operations, causing among others environmental costs in terms of higher resources needed for such operations.

The European Commission has requested further input concerning the above mentioned areas, as a means of understanding

- the share of products affected;
- manufacturers' technical or procedural difficulties with compliance with the RoHS Directive, as well as the association of such difficulties with specific product components and with specific parts of the supply chain;
- possible economic, social and environmental impacts of the current legal situation; and
- possible solutions that may facilitate compliance;

Oeko-Institut, supported by Eunomia, has been appointed by the European Commission², to provide an analysis of possible economic, social and environmental impacts related to the above mentioned areas of review. This analysis is to regard three main areas:

- Non-road mobile machinery without an on-board power source;
- Windows and doors with electric functions; and
- Refurbishment practices, where spare parts are recovered from EEE not compliant with RoHS, refurbished and reused for the repair of EEE devices to be made available on the EU market.

² Contract is implemented through Framework Contract No. ENV.C.2/FRA/2011/0020 led by Eunomia

1.2 Objectives

The Commission has requested a detailed assessment of the impacts of RoHS 2 on the following three areas of review, with a view to a possible legal adjustment:

- non-road mobile machinery;
- windows and doors with electric functions; and
- the refurbishment of medical devices.

Against the background detailed above, the following objectives were specified for this project:

- Assessment of the impacts of RoHS 2 on the three specific EEE sectors / economic operation. This assessment shall include:
 - Outline of the scope of the problem in terms of the products or operations of relevance in the context of compliance with RoHS 2 Article 4(1);
 - Compilation of information and data collected from stakeholders and from additional public sources;
 - Attempt to quantify the problem on the basis of available data concerning the type and volume of products; where quantified data is not available, this shall be done on a qualitative basis;
 - Identification of possible economic, social and environmental impacts of the current situation and their magnitude, where available data allows a quantification;
 - Suggestion of possible solutions, targeted at alleviating adverse impacts where such are to be expected; and
 - Preparation of a report to present collected information, assessment, conclusions and recommendations.
- Direct consultation with stakeholders aimed at collecting information on the three areas of review.

The compiled information prepared as a result of the above mentioned analysis is presented separately for each of the three areas of review.

- Input concerning “Non-Road Mobile Machinery in the Context of RoHS” is presented in Section 2.0;
- Input concerning “Windows and Doors with Electric Functions ” is presented in Section 3.0; and
- Input concerning “Refurbishment of Medical Devices in the Context of RoHS” is presented in Section 4.0.

2.0 Non-Road Mobile Machinery in the Context of RoHS

2.1 Abbreviations

| | |
|----------|--|
| CECE | The Committee for European Construction Equipment |
| CEMA | The Agricultural Machinery Industry in Europe |
| Cr VI | Hexavalent Chromium |
| EEE | Electrical and Electronic Equipment |
| EUROMOT | The European Association of Internal Combustion Engine Manufacturers |
| EUROPGEN | The European Generation Set Association |
| GENSETS | Generation sets |
| LSFI | Large Scale Fixed Installation |
| NAM | The National Association for Manufacturers |
| NRMM | Non-road mobile machinery |
| Pb | Lead |
| PTO | Power Take Off (of a vehicle) |
| OEM | Original Equipment Manufacturer |
| RoHS 2 | Directive 2011/65/EU |
| SME | Small and Medium Enterprises |

2.2 Introduction

With the coming into force of Directive 2011/65/EU (RoHS 2), an open scope has been adopted concerning products that need to comply with the substance restrictions as well as with other administrative obligations. To accommodate this change, the new Category 11 was added to Annex I of the Directive, which lists the relevant product categories that are in scope.

Category 11 is specified as “Other EEE [electrical and electronic equipment] not covered by any of the categories listed above”. This means that any EEE that does not fall under categories 1-10 and was understood to be excluded from RoHS 1 is now in the scope of RoHS 2. In cases where such equipment falls under the EEE definition and does not benefit from one of the Article 2(4) exclusions, it would need to comply with the substance restrictions as with other RoHS obligations.

Non-road mobile machinery (NRMM) is excluded from the scope of RoHS 2 via Article 2(4)(g), with Article 3(28) providing a definition for NRMM to clarify what types of equipment could benefit from this provision (see detail in Section 2.3). However

stakeholders have raised concern that in some cases, the formulation of this exclusion results in very similar types of equipment being regulated inconsistently.

The definition of non-road mobile machinery in Article 3(28) requires an on-board power source. According to industry, the same type of equipment is however available with and without an on-board power source (e.g. professional floor cleaning machines). The identical EEE with external power source (cable) is currently in scope despite the similarities of such devices to models that are not in scope (with an on-board power source). Concern has been raised that compliance in such cases may result in significant costs.

The Commission has thus found it necessary to perform a review of the impacts of RoHS 2 on NRMM, to understand the scope of the problem and possible options for resolving it, possibly through exemptions.

This study has thus attempted to review products which may be affected and to assess manufacturers' technical or procedural problems with RoHS compliance of NRMM. Analysis was also aimed at understanding where in the product and in the supply chain the problems can be located and tackled.

2.3 Legal Background

According to Article 3(1) of RoHS:

“,electrical and electronic equipment’ or ‘EEE’ means equipment which is dependent on electric currents or electromagnetic fields in order to work properly and equipment for the generation, transfer and measurement of such currents and fields and designed for use with a voltage rating not exceeding 1,000 volts for alternating current and 1,500 volts for direct current;”

Article 3(2) further details that:

“for the purposes of point 1, ‘dependent ‘ means, with regard to EEE, needing electric currents or electromagnetic fields to fulfil at least one intended function;”

In light of the addition of an open-scope, all products and devices covered by these definitions are understood to be in the scope of RoHS and to be required to comply with the various obligations stipulated in the legal text. EEE that is newly in scope and that does not fall under categories 1-10 of Annex I of the Directive is thus understood to fall under category 11, which refers to other EEE not covered by any of the other categories.

In parallel, Article 2(4) provides a number of exclusions for specific types of equipment. These are the only types of EEE which are excluded and do not need to comply with the Directive. Among others, non-road mobile machinery (NRMM) is excluded from the scope via Article 2(4)(g):

“(non-road mobile machinery made available exclusively for professional use;”

Article 3(28) explains that:

“non-road mobile machinery made available exclusively for professional use’ means machinery, with an on-board power source, the operation of which requires either mobility or continuous or semi-continuous movement between a succession of fixed working locations while working, and is made available exclusively for professional use.”

However according to stakeholders there are certain types of professional equipment for which some models shall be equipped with an on-board power source, with others having an external source and thus equipped with a cable. In cases where such equipment is almost identical, there is concern that compliance with the substance restrictions may result in substantial costs. As shall be explained below, information provided by stakeholders has allowed identifying three product groups with the above mentioned problem.

Other stakeholders have provided information concerning certain product groups of professional equipment which are mobilized in between working locations but currently do not benefit from the RoHS NRMM exclusion as the equipment is not operated during mobilization. One example is generating sets (GENSETs) which are mounted onto trailer trucks to allow their transport from one location to another. GENSETs are often excluded through Article 2(4)(e) as large scale fixed installations (LSFI) in light of their size and their permanent use at a fixed location. However, in cases where the equipment is mobilized, such as when used for disaster relief purposes, the same equipment cannot benefit from the LSFI exclusion in light of its mobility. Though the equipment is understood to be non-road mobile machinery it would not be covered by the NRMM exclusion, based on the Article 3(28) definition, as the equipment is not mobile when in use but rather in between uses.

LSFI are defined by Article 3(4) as:

“large-scale fixed installation’ means a large-scale combination of several types of apparatus and, where applicable, other devices, which are assembled and installed by professionals, intended to be used permanently in a pre-defined and dedicated location, and de-installed by professionals”

Stakeholders further claim that the reference to the requirement “mobility... while working” is not included in the NRMM Directive (see Section 2.4) and that there are thus inconsistencies with the RoHS directive.

2.4 Product Group Description and Background

The NRMM Directive³ stipulates test procedures and regulates exhaust emissions from different types of engines. Directive 97/68/EC (the "main" directive) covers **diesel fuelled engines** for common NRMM. It became effective from 1 January 1999 for certain types of engines. Its first stages cover diesel fuelled engines between 37 and 560 kW. Directive 2002/88/EC, extends the scope of 97/68/EC to cover **spark ignited engines (petrol engines)** up to 18 kW for engines installed in handheld and non-handheld equipment. Directive 2004/26/EC (amendment) extends the scope of 97/68/EC, which covers diesel fuelled engines from 19 kW to 560kW for common NRMM and regulates the emissions in 3 further stages. The directive includes **constant speed engines** as well as **railway** and **inland maritime engines** (inland waterway transport sector). Though additional amendments of the Directive exist, they do not further extend the scope of machinery which is in scope.

Article 2 of Directive 97/68/EC⁴ and its amendments, defines “*non-road mobile machinery shall mean any mobile machine, transportable industrial equipment or vehicle with or without body work, not intended for the use of passenger- or goods-transport on the road, in which an internal combustion engine as specified in Annex I section 1 is installed*”. In this sense, it is possible that the definition of NRMM under RoHS 2 was formulated to include the “on-board power source” since Directive 97/68/EC defines NRMM among others on the basis of having an integral combustion engine.

The consultants would also like to draw attention to the reference to mobile machinery, transportable industrial equipment and vehicles. It seems clear that a “vehicle” is mobile while working and the same could be assumed for “mobile machinery”. In this second case, the word mobile is used to make a distinction from other machinery, which is thus understood not to be mobile. This is further supported by Article 3(16) of Directive 2007/46/EC⁵, according to which:

“mobile machinery’ means any self-propelled vehicle which is designed and constructed specifically to perform work which, because of its construction characteristics, is not suitable for carrying passengers or for transporting goods.

³ The EU legislative file of Non-Road Mobile Machinery (NRMM) currently contains seven directives: the "main" Directive 97/68/EC, and its amendments: Directive 2002/88/EC, Directive 2004/26/EC, Directive 2006/105/EC, Directive 2010/26/EU, Directive 2011/88/EU and Directive 2012/46/EU. See http://ec.europa.eu/enterprise/sectors/mechanical/documents/legislation/emissions-non-road/index_en.htm for further information.

⁴ DIRECTIVE 97/68/EC OF THE EUROPEAN PARLIAMENT AND OF THE COUNCIL of 16 December 1997 on the approximation of the laws of the Member States relating to measures against the emission of gaseous and particulate pollutants from internal combustion engines to be installed in non-road mobile machinery, Consolidated version of 10.01.2013, available under: <http://eur-lex.europa.eu/LexUriServ/LexUriServ.do?uri=CONSLEG:1997L0068:20130110:EN:PDF>

⁵ Directive 2007/46/EC of the European Parliament and of the Council of 5 September 2007 establishing a framework for the approval of motor vehicles and their trailers, and of systems, components and separate technical units intended for such vehicles, available under <http://eur-lex.europa.eu/legal-content/EN/TXT/PDF/?uri=CELEX:32007L0046&from=EN>

Machinery mounted on a motor vehicle chassis shall not be considered as mobile machinery;”

The third formulation “transportable industrial equipment” however creates a separation between the type of equipment (industrial) and its mobility. The consultants interpret this to mean that the equipment can be transported from place to place, without its needing to be dis-installed and re-installed to enable mobility. However it remains unclear if this applies to mobility between work sites, to mobility while working or to both.

2.4.1 Problem Definition

As shortly discussed above, stakeholders have raised two types of equipment which they understand to be relevant to the review concerning NRMM. These contributions are summarised in Appendix A.1.0. Two main aspects have been raised by stakeholders regarding NRMM.

The first concerns machinery understood to be **NRMM**, for which there exist models **with an on-board power source** as well as models **with an external power source**. In light of the reference of the Articles 3(28) definition to an on-board power source, only the first would be excluded from the scope of RoHS. Relevant product groups include professional cleaning machinery; agricultural machinery (trailers and interchangeable towed equipment); and certain types of construction machinery. From the various models in the above mentioned product groups, only those with an integral combustion engine would be understood to be NRMM according to Directive 97/68/EC. However, according to the RoHS definition, there is no requirement for the on-board power source to be a combustion engine. This means, for example, that machinery with an on-board battery source could also benefit from the exclusion if other aspects of the RoHS NRMM definition are fulfilled.

The second concerns **large scale machinery used at multiple locations**, which would normally benefit from the RoHS exclusion as LSFI, but in this specific case is understood not to benefit from this exclusion in light of being portable. Despite the mobility aspect, it is unclear if the equipment would fall under the RoHS definition of NRMM as it is **not operated during mobilisation**. Relevant product groups include machinery using certain engine models which are sometimes classified in scope and sometimes out of scope, namely mobile electrical generators; petroleum extraction equipment; and industrial power systems. On the basis of the definition provided in the NRMM Directive, though it is said that such equipment would be understood to fall under 97/68/EC, it is unclear if it would be covered by the RoHS definition of NRMM in light of its operation only at fixed locations.

Both of these cases show that there are inconsistencies in the definitions of NRMM between the two Directives. Though it is not the purpose of this review to look into intra-Directive inconsistencies, this aspect should be noted in the case of an amendment of the current RoHS definition of NRMM (Article 3(28)). What becomes clear, however, is that the various aspects included in the wording formulation of Article 3(28), create cases in which similar equipment is in some cases required to comply with the substance restrictions, and in other cases is not. According to

stakeholders, in these cases, the current regulation shall result in compliance costs that are not justified by the expected environmental benefits.

2.4.2 NRMM with and without an On-Board Power Source

Three stakeholders provided information concerning NRMM inconsistently addressed by the NRMM exclusion. For such equipment there exist models, with an external power source (equipped with a cable), that are very similar to models with on-board power sources. Contributions were provided by three industry associations, with one of the contributions also supported by a cleaning machinery manufacturer.

The Committee for European Construction Equipment (CECE)⁶ explains that NRMM is excluded from the scope of the RoHS 2 Directive (Article 2(4)(g)). However, that the definition of non-road mobile machinery in the legal text limits its applicability to machinery with an on-board power source – contrary to other EU legislation defining the term of “NRMM”. Consequently cable-powered machinery would be in the scope of RoHS, regardless if all other conditions of the definition are fulfilled.

The NRMM Directive does not refer to an “on-board power source” in its definition for NRMM. However the consultants note that this Directive’s definition of NRMM requires that “an internal combustion engine as specified in Annex I section 1 is installed” in the machinery/equipment/vehicle.

Eunited Cleaning, the European Cleaning Machines Association⁷, provides information concerning **professional cleaning machines**. Examples include sweepers and scrubber driers, which are cord-connected, and that would thus be required to comply with the substance restrictions. Eunited Cleaning explains that the same products exist with an on-board power source, which would benefit from the exclusion. All in all Eunited Cleaning estimates that over 70,000 units are placed on the EU market per annum, with a distribution between models with an on-board power source and models without (cord connected) of 80:20.

EUnited Cleaning contends that in general, manufacturing companies are quite small in size, with the largest manufacturer having around 11,000 employees and the second largest manufacturer being half of this size. Most manufacturers are assumed to be close in size to SMEs or possibly slightly larger. It is further expected that all manufacturers produce both machines in on-board power source versions and in cable operated versions. This is a result of the similarity of such versions and of the fact that the power supply is configured according to the client’s preference.⁸

⁶ CECE (2014a), CECE Answers to NRMM Questionnaire, submitted per email on 05.12.2014

⁷ EUnited Cleaning (2014b), EUnited Cleaning Answers to NRMM Questionnaire, submitted per email on 28.11.2014

⁸ EUnited Cleaning (2014c), Summary of telephone conference with Charalambos Freed and Axel Leschtar, held 4.12.2014

According to EUnited Cleaning⁹ in cleaning machinery that could potentially benefit from the NRMM exclusion in Article 2(4), versions with an on-board power source will either have a battery similar to a car battery (Pb battery or Li-Ion battery, but not Cd battery) or work with a combustion engine running on diesel/petrol. Others will be cord-connected. For different models, both versions shall usually exist in light of customer preferences, whereas aside from the power supply the machines shall be almost identical in their design (see example in Figure 2-1 below). In this regard, it is estimated that above 95% of components are exactly the same and are manufactured on the same production line.

Figure 2-1: Pictures of identical machines with an on-board power source and cord connected for professional use.

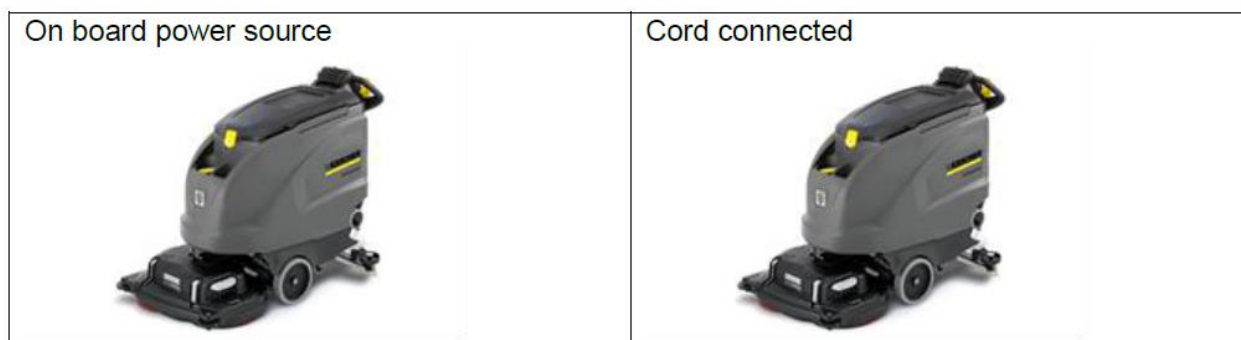

Source: EUnited Cleaning (2014d), Letter with Request/Comments Concerning RoHS 2, Definitions, sent per email on 8.12.2014

EUnited Cleaning¹⁰ explains that there are various reasons why some customers prefer the cord connected models, and others prefer models with an on-board power source, including:

- That the cable (or cord) connected models are in most cases cheaper;
- That having a battery operated machine requires the machine to be recharged from time to time and is in this respect less convenient for operation due to the loss of working time;
- Nonetheless, in some cases a cable connected version cannot be used as logistically the room to be cleaned is too large (length of cable not practical) or the amount of passers-by would raise the risk of accidents significantly (for example in airports);
- In a small part of models, battery operated models may also be heavier;

Concerning the presence of ROHS substances, EUnited Cleaning estimates that these are present in negligible concentrations in relation to the [weight of the] machine. RoHS substances are expected to be present in printed circuit boards; switches; and

⁹ Op. cit. EUnited Cleaning (2014c)

¹⁰ Op. cit. EUnited Cleaning (2014c)

different electronic components, all in very small quantities. The mechanical demands of such machinery through use make finding suitable substitutes very difficult, as machinery is exposed for example to in-harmonic vibrations and to corrosive heavy duty cleaning materials. ¹¹ During operation, strict requirements are put on all devices in terms of quality and safety. Factors include: ¹²

- Strong vibration;
- The effects of weather and road salt;
- Use of acid or alkaline cleaning agents;

The fact that cleaning machines operate with heavy-duty chemicals adds to the aspects of reliability that need to be considered when researching for substitutes, as faults of machinery resulting in leaks can result in emissions of chemicals and thus in impacts to the environment and to the health of operators and passers-by. ¹³

Possible alternatives are limited and not yet tested for suitability for these types of machines. For example, *“ROHS compliant alternatives must meet these requirements, e.g., secure solder joints, despite the use of lead-free solders, reliable corrosion protection, despite absence of chromium(VI), safe electrical lines, despite phasing out of lead and cadmium. Testing for one product part takes approx. 12-18 months and no guarantee it works. Implementation in safety standard → 3-4 years”*. EUnited Cleaning expects that manufacturers shall have high compliance costs in light of the need to find reliable alternatives and the costs and time needed for doing so. ¹⁴

It is however expected that as substitutes become more and more available for other products/machinery, there is a good chance that professional cleaning machinery shall also become more and more RoHS conform, as the cleaning machinery market share is too small for suppliers to manufacture components only for their use in such products. In other words, regardless of the question if such products shall remain in the scope of RoHS, compliance (and in this sense the respective environmental benefits that could result from compliance) is likely to be achieved in-directly in light of a decreasing supply of components which are not compliant with RoHS. ¹⁵

¹¹ Op. cit. EUnited Cleaning (2014b)

¹² EUnited Cleaning (2014a), EUnited Cleaning Letter to European Commission Concerning time frame Restriction of Hazardous Substances (RoHS, Directive 2011/65/EU) , submitted per email on 5.3.2014

¹³ Op. cit. EUnited Cleaning (2014c)

¹⁴ Op. cit. EUnited Cleaning (2014b)

¹⁵ Op. cit. EUnited Cleaning (2014c)

They propose resolving this the current problems by changing the Article 3(28) definition where the power source is mentioned as follows (addition in italics): “...with an on-board power source *or with a traction drive...*”¹⁶.

CEMA¹⁷ represents the Agricultural Machinery Industry in Europe, and has provided information concerning **agricultural NRMM**. This encompasses agricultural vehicles like tractors (category T), interchangeable towed equipment (category S) and agricultural trailers (category R) that fall under type approval like cars and trucks, and also agricultural non-road mobile machinery.

It is understood that in light of the definition of NRMM in Article 3(28), tractors and agricultural self-propelled machines are excluded from the scope of RoHS and do not need to comply with the substance restrictions. Agricultural trailers and interchangeable towed equipment (categories R and S respectively) however, do not benefit from this exclusion in light of the reference to ‘with an on-board power source’ of this definition.¹⁸

It is however possible that they are excluded through Article 2(4)(c)¹⁹ as the connection of these vehicles is only possible to tractors (which are excluded) and they are dedicated to a specialised function. According to CEMA, the interchangeable towed equipment are in fact machines under the Machinery Directive for dedicated functions (balers, towed spraying equipment, towed ploughing equipment, towed seeding equipment, towed harvesting equipment...) for professional use only. For road safety reasons they fall under the framework regulation for agricultural vehicles (167/2013).²⁰ CEMA adds to this explanation that the only issue of uncertainty for the exclusion of agricultural trailers and interchangeable towed equipment through Article 2(4)(c) may be the wording reference to “equipment which...is to be installed” as such vehicles are rather coupled and decoupled, and not installed.²¹

“99 % of interchangeable towed equipment receives its power from the power take off (PTO) of the tractor. This powers mechanically special tools on the towed vehicle. Less than 1 % of such vehicles are powered by electricity from the tractor, where ‘electrification’ is needed on the tractor to generate the high voltage necessary to power the different tools. The electronic equipment on board of the towed equipment is necessary to direct the different tools,

¹⁶ EUnited Cleaning (2014d), Letter with Request/Comments Concerning RoHS 2, Definitions, sent per email on 8.12.2014

¹⁷ CEMA (2014a), Personal communication titled “CEMA request – related to the analysis of impacts from RoHS 2 on various products: non-road mobile machinery without an on-board power source”, sent per email on 7.10.2104.

¹⁸ CEMA (2014b), CEMA Answers to NRMM Questionnaire, submitted per email on 03.12.2014.

¹⁹ Directive 2011/65/EU Article 2(4)(c) reads: “equipment which is specifically designed, and is to be installed, as part of another type of equipment that is excluded or does not fall within the scope of this Directive, which can fulfil its function only if it is part of that equipment, and which can be replaced only by the same specifically designed equipment;”

²⁰ Op. cit. CEMA (2014a)

²¹ Op. cit. CEMA (2014b)

providing them the necessary intelligence. The electronic equipment used is from suppliers that deliver components also to trucks and off-road vehicles. The agricultural vehicle sector is too small to have dedicated suppliers. As for agricultural trailers, some of them are equipped with tools on the back e.g. as in the case of a manure spreader. In addition any towed machine whose ratio between laden and unladen mass is higher than 3 is also seen as a trailer... These are dedicated vehicles, exclusively used by professionals, under very harsh conditions, pulled by tractors that are excluded from the scope as well".²²

CEMA²³ explains that in total the agricultural machinery park has around 450 different types of machines. Many of these types are interchangeable towed equipment. Comprehensive data for EU sales of the main interchangeable towed equipment in the EU28 is not available, however to provide some insight, volumes for the 'Sowing, Fertilizing, Plant Protection' equipment (turn-over of €1.5 Billion) were detailed as follows:

- *"Towed sprayers: around 10.000 units against 1000 units self-propelled*
- *Fertiliser spreaders: around 20.000 units*
- *Seed drills: 20.000 units*
- *Precision seed drills: 60.000 units"*

Of a total turnover for the agricultural machinery industry of around €29.8 billion in 2013, it is estimated that R&S vehicles/mounted implements count for about €8.4 Billion or 29 %. Agricultural trailers are said to have a total turnover of less than a Billion €, having only little electronics on-board (for instance anti-lock braking (ABS) systems). As for the volume of sales for such products, for a specific model, this can range from 1 per year up to several hundred per type but no more [the consultants understand this to mean that the sales of a specific model is one to several hundred per annum] . The larger-sized companies, specialised in R&S vehicles can have total production volumes of up to 20,000 units. Figure 2-2, shows a distribution of the number of companies and their total production volumes for Spain, giving an idea as to how many small manufacturers are present in this market.²⁴

²² Op. cit. CEMA (2014a)

²³ Op. cit. CEMA (2014b)

²⁴ Op. cit. CEMA (2014b)

Figure 2-2: Number of Companies Versus their Annual Production of R&S Vehicles (Spain 2012 - 1000 manufacturers)

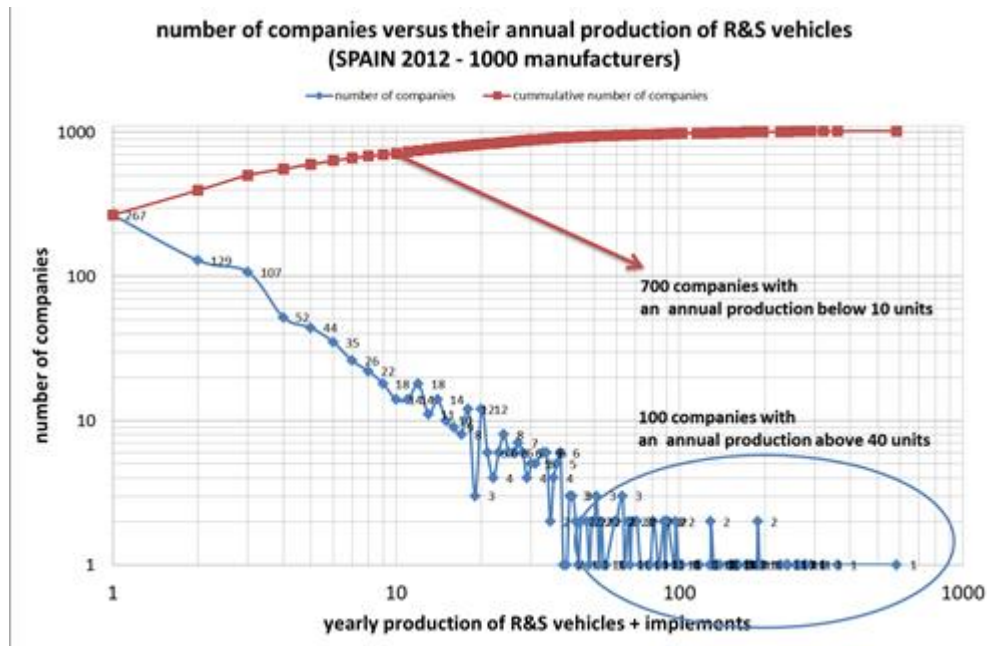

Notes: “Even the large companies like Pöttinger, Lemken, Kuhn, Maschio Gaspardo, Kverneland... have low production volumes per type but many types. For example, for one company for which detailed information was provided to CEMA on volumes/types: the company had 7 different classes of machines like a loaderwagen, mower, teder... with in total of 72 types (separately type approved) with total production volume of 8,396 units (3,110 for the EU).

Source: Op. cit. CEMA (2014b)

As for compliance with RoHS, CEMA²⁵ explains that the agricultural machinery industry has always been excluded from the RoHS directive. The exclusion of the automotive industry was always based on the more harsh environments under which such vehicles operate and on the safety requirements. Most components are the same or similar to those from the bigger automotive sectors. Therefore, when it comes to electronic components, manufacturers are mostly “followers” [i.e., do not have sufficient power to influence the design of supplied components] . A thorough analysis of the composition of electronic components has never been performed for this sector, with the exemption of some major manufacturers when the RoHS Directive was first launched. On this basis, CEMA could not provide information concerning the use of RoHS substances or concerning the availability of substitutes. Nonetheless, CEMA assumes that since for most electronic suppliers it was not feasible to continue manufacturing non-compliant electronic components solely for the automotive industry, that in some areas compliance may have already occurred for electronic components. As for the compliance of non-electronic parts, this could be a source for heavy compliance costs, as such components would also need to comply.

²⁵ Op. cit. CEMA (2014b)

The Committee for European Construction Equipment (CECE)²⁶ has provided information concerning **construction and mining equipment**.. According to CECE, several types of construction machinery are electric powered, and thus have cables that provide a power source, rather than an on-board engine. For example, the following machines, used primarily in mining, which are practically identical to diesel powered (or gas powered) NRMM in every other respect:

- Underground Coal Shuttle Cars (these products would likely fall under the “means of transportation” exclusion”).
- Underground Hard Rock Jumbo Drill – these products have a diesel engine drivetrain, but a trailing cable supplies power while drilling.
- Underground Rock Header.
- Rotary blast hole drills - this machine type includes both diesel and electric trailing cable models.
- Underground Coal Roof bolters.
- Underground Coal Continuous Miners.
- Electric Rope Shovels.
- Draglines.
- Hydraulic Mining Shovels - current models can be provided with external cable power source and on-board power source.
- Hauling trucks equipped with trolley system – these also likely fall within the “means of transportation” exclusion).

CECE does not have detailed statistics as to the electric powered NRM mining machinery market, however estimates the EU market share to be relatively low compared to the global market. Because of the size, expense and operating costs of these products, the market is for professional use in mines only, so a niche market exists for all of these products in mines in the EU. For example, approximately 40-80 electric shuttle cars are operating in coal mines in the EU, as well as a small number of electric rope shovels, and continuous miners. These products can be as large as a three story building and cost multiple millions of Euros. The total sales of each individual product is relatively low globally. For products that are available both with an on-board or with an electric power source, the customer has the option of selecting which model is preferred for its mine. Because of the small number of large mining machines available for sale annually, the share of electric machines varies widely from year to year. For the most part, however, many of the mining products are available only in electric versions, but these non-road electric powered mobile machines use many of the same components as the diesel and gas powered electric machines.²⁷

²⁶ Op. cit. CECE (2014a)

²⁷ Op. cit. CECE (2014a)

CECE explains that mining and construction equipment is typically operated in extremely harsh conditions and is constantly exposed to debris and vibration while expected to operate for thousands of hours. These products operate in a wide range of climates, some of which can be extreme due to the location of the job site. This type of equipment requires more durability and reliability than relevant consumer products because of the industrial setting and application. All mining and construction equipment are held to very high safety standards because of the close proximity to people while in use. Converting mining and construction equipment to RoHS compliant components may degrade the quality and durability of safety critical components and put operators and bystanders at risk. Lead-free solder is significantly more brittle than leaded solder and therefore is less able to function in extreme conditions. More work is required to validate its use on construction and mining machines.²⁸

Concerning presence of RoHS substances, CECE contend that as NRMM has up till now been excluded from RoHS, an analysis regarding “RoHS substances” has not yet been performed by construction equipment manufacturers. Such an analysis would largely depend on suppliers of such manufacturers to provide them with the information. Undertaking such an analysis is presumed to be a complex challenge for the industry. This is on the basis that manufacturers of the construction equipment sector develop and produce thousands of applications, many for niche markets with sales of less than one hundred units per year and even down to series of less than 10 units per year. As for complying with RoHS, manufacturers would face very similar technical challenges to make machines without on-board power source compliant with RoHS as they would for machines with on-board power source, because many components of these machines are very similar such as many electronic components on these machines. Such technical challenges could potentially prevent manufacturers from producing and placing RoHS compliant machines without on-board power source on the EU market, especially when similar machines with on-board power source are excluded.²⁹

2.4.3 Mobilised Machinery Operated at Fixed Locations

Four stakeholders provided information concerning NRMM, which is mobilised in between fixed working locations – three industry associations and one manufacturer of relevant equipment (diesel engines). The case for such machinery is based on two main arguments. The one concerning the inconsistency between the RoHS Directive NRMM definition and other legislation, and the other, in relation to the similarity of equipment in scope to other equipment, which is excluded. It is explained that in some cases identical equipment is treated differently in light of the dissimilarities in installation.

²⁸ Op. cit. CECE (2014a)

²⁹ Op. cit. CECE (2014a)

EUROMOT³⁰, the European Association of Internal Combustion Engine Manufacturers, explains that reciprocating engine models and families are applied across many end-use applications. The same basic engine model may be used in earthmoving equipment, generation sets (gen-sets) and marine engines. Engines used in earthmoving machinery are excluded on the basis of Article 2(4)(g) & 3(28) as they are professional use, have an on-board power supply, and their operation requires either mobility or continuous or semi-continuous movement between a succession of fixed working locations while working. Similarly engines used in means of transport, such as marine vessels, are out of scope according to article 2(4)(f). However, it could be interpreted that certain machines characterised as ‘non-road mobile machinery’ in the engine exhaust emission legislation 97/68/EC are not considered to be non-road mobile machinery under article 3(28) of 2011/65/EU, such as mobile gen-sets.

EUROPGEN³¹, the European Generation Set Association, explains that diesel engines are utilized in a broad array of end use applications due to their efficiency and reliability. Because of the many marketable uses of diesel power, a single engine platform, identical in design and construction, is commonly used in multiple applications. However, these end-use applications are regulated inconsistently. Permanently installed generating sets for either standby or continuous duty with power ratings greater than 375 kW are typically excluded from the RoHS Directive as ‘Large Scale Fixed Installations’. Identical models are also extensively used for temporary power at e.g., construction sites, disaster recovery zones and public events. Due to their temporary nature [in terms of location], these products do not benefit from the LSFI exclusion since they are moved from site to site and are not permanently installed at a pre-defined and dedicated location. Generators for non-permanent installations (e.g., rental application) utilize the same engine as the previous examples and are destined for very similar use: back-up power for critical applications such as communications equipment, data centres, refrigeration, and medical facilities. These would also not benefit from the NRMM exclusion, nor would they fall under the LSFI exclusion.

Similarly, NAM³², the National Association for Manufacturers, names mobile electric generators, petroleum extraction equipment and industrial power systems as professional product applications which are mobile in so far as they are intended to move between multiple job sites over the course of their useful life. These three types of equipment use the same “on-board power source” (an internal combustion engine) as well as other components applied in machines that are excluded from the scope of the Directive, however they are mobilised in between working locations and thus would not be covered by neither the NRMM nor the LSFI exclusions..

The current definition of NRMM, that is “machinery, with an on-board power source, the operation of which requires either mobility or continuous or semi-continuous

³⁰ EUROMOT (2014b), EUROMOT Answers to NRMM Questionnaire, submitted per email on 2.12.2014.

³¹ EUROPGEN (2014a), EUROPGEN Answers to NRMM Questionnaire, submitted per email on 2.12.2014.

³² NAM (2014a), NAM Answers to NRMM Questionnaire, submitted per email on 2.12.2014.

movement between a succession of fixed working locations while working...” does not apply to static generating sets, whether they are permanent or temporary as there is no mobility while working.³³

The rated power output of the power generation equipment in question is between 375kW to ~2.5 megawatts. Power generation equipment is currently manufactured and sold in all ranges in this power spectrum, with most of it benefiting from the LSFI exclusion, however with some not qualifying due to the fact that it is mobile while not in use. The products are engineered to be overhauled, which can effectively extend the useful life for an indefinite term. Generating sets above 375kW have a typical life of over 20 years. They are unlikely to enter the waste stream or end up in land fill as they contain precious metals and large quantities of recyclable materials. Generating sets such as these are also within scope of Directive 2012/19/EU (WEEE) and carry obligations on the manufacturer or seller. Table 2-1 below shows global market estimates of sales volume and turnover by kVA output. EUROPGEN estimates that the RoHS restrictions on temporary, non-stationary generating sets will have an impact throughout the power generation industry and also throughout the engine manufacturers’.³⁴

Table 2-1: 2013 Diesel Gen-Set Market, Parkinson’s data

| Power Band (kVA) | World | | Europe | | Europe % World | |
|------------------|-------------------|------------------|------------------|---------------|----------------|-----------|
| | Euro 000 | Units | Euro 000 | Units | Euro 000 | Units |
| <7.5 | 910,928 | 608,705 | 54,295 | 33,266 | 6% | 5% |
| 7.5-250 | 3,357,914 | 507,664 | 408,023 | 50,241 | 12% | 10% |
| 251-750 | 1,989,620 | 71,025 | 242,811 | 8,453 | 12% | 12% |
| 751-2000 | 2,096,338 | 23,782 | 240,945 | 2,410 | 11% | 10% |
| 2000+ | 2,142,948 | 5,067 | 356,196 | 667 | 17% | 13% |
| Total | 10,497,747 | 1,216,243 | 1,302,270 | 95,037 | 12% | 8% |

Source: Submitted in both EOROGEN (2014a) and EUROMOT (2014a)

Lead is explained to be the primary RoHS substance of concern. Typically lead is present in engine bearings, some electronic and cooling system components, and in some aluminium and copper alloys used in precision components such as housings, covers, connectors, and fittings. Lead quantities in these components can be above the restriction threshold at the homogeneous material level, though it is explained that it is present in very small quantities relative to the mass of the generating set. As an example, an audit of an electronic fuel injection diesel engine producing approximately 1800 kW electricity is given. The audit showed that the engine contained 16 grams of lead in total. This engine is similar in design and consistent in materials and supplies used to other larger diesel engines. A typical weight of a generating set employing such an engine would be 20 tonnes. On the basis of the

³³ Op. cit. EUROPGEN (2014a)

³⁴ Op. cit. EUROPGEN (2014a)

2013 total volumes from the Parkinson table above and using 16g per unit as a conservative estimate, EUROGEN estimate that a total of 1521 kg of lead could be placed on the EU Market through the sales of example products. It is further emphasized that this estimate is extremely conservative with the quantity per engine based on the larger engine sizes with relatively low volumes (3,077) whereas smaller engines (91,960) contain much less lead.³⁵

EUROMOT³⁶ explains that lead is present as an alloy element or thin layer in engine bearings and bushings, used for some components of complete engine packages including air compressors and starters. Of greatest concern is lead used in larger size main and connecting rod bearings where no effective substitute has yet been developed. On a typical tri-metal bearing for heavy duty application, the very thin overlay may contain up to 90% lead and the bearing alloy may be up to 20% lead (see Figure 2-3 below). Lead would typically comprise between 1 and 3% of a complete leaded bearing (based on total part weight). Lead from all these components would typically comprise less than 0.025% of a complete engine. This does not include RoHS compliant trace amounts of lead that may be in standard steel and aluminium alloys.

Figure 2-3: Tri-metal Bearing Illustration

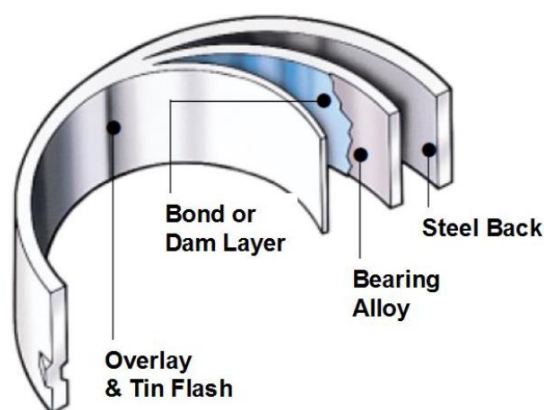

Source: EUROMOT (2014a)

It is not completely clear to the consultants how the EUROMOT and EUROGEN statements concerning the possible Pb content of a complete engine correspond with each other. EUROMOT estimate that the total Pb from the components it details in “a complete engine” would comprise less than 0.025% of it. It is assumed that this statement regards the %weight of the Pb from the engine weight. EUROGEN estimate that a total of 16 gr of Pb would be present in a “generating set employing such an engine”. The weight of a typical generating set is estimated by EUROGEN to be 20 tonnes. This would suggest that the weight of the engine would need to be around

³⁵ Op. cit. EUROGEN (2014a)

³⁶ Op. cit. EUROMOT (2014b)

640 Kg, for 16 gr of Pb to represent 0.025% of the engines weight as estimated by EUROMOT.

Concerning substitution of RoHS substances, EUROPGEN explain that Lead-free bearings have been developed and tested for smaller (typically automotive) engines. However the technology for lead-free bearings in larger engines is not fully developed. Early indications show that the lead-free bearing alternatives are not as reliable in service, requiring more frequent major engine overhauls. This would create a significantly larger waste stream of consumable items, including used oil, coolant, gasket and sealant materials as well as the bearings themselves and therefore the impact to the overall waste stream could be considerably higher than when using the leaded bearing materials, where the mass of lead is very small. Significant research and development is still needed, particularly for larger engines.³⁷

NAM³⁸, elaborate on this, explaining that while work on alternatives is underway, using lead bearings in these applications remains the only way to ensure most engine debris embeds safely in the bearing. This allows the equipment to deliver the critical performance, reliability and durability necessary for power generation in multi-complex operational environments.

Lead-free solders for electronic components have been developed and industry is working toward introduction. However, such solders are significantly more brittle than leaded solder and more work is required to validate their use for on-engine applications such as the larger engine control modules. Lead-free solders for cooling system components such as radiators are still undergoing trials. In this regard, it is also explained that any impact on reliability will have a negative effect on the end users of the power generation equipment. This is particularly important when the generating sets are providing backup power to hospitals or other critical support systems.³⁹

EUROPGEN explain that the industry is diligently trying to work to the stated deadline but the outcome is uncertain for the reasons stated above. Many bearing manufacturers have conducted prototype and bench testing of RoHS compliant bearings for the >375 kW market segment, but none have undergone successful engine validation testing (~ 3years) and field testing (~3 years) nor are lead free bearings utilized as a leaded bearing substitute in critical power generation applications. It may not be possible to deliver a cost-effective compliant product with an acceptable reliability within the given timeframe. If this occurs, this may result in many companies removing product lines from the EU market, giving an unfavourable impact to the EU economy, including manufacturing industries, infrastructure and product end users (increased capital expenditure and period costs).⁴⁰

³⁷ Op. cit. EUROPGEN (2014a)

³⁸ Op. cit. NAM (2014a)

³⁹ Op. cit. EUROPGEN (2014a)

⁴⁰ Op. cit. EUROPGEN (2014a)

2.5 Applicability of the RoHS Article 2(4) Exclusions

As explained above, stakeholders have addressed two types of equipment, which are said to be regulated inconsistently. Thus an important aspect in terms of compliance is to understand how these product groups relate to the NRMM definitions.

In one case, the aspect raised is related to the power source. The RoHS NRMM definition depends on the existence of an on-board power source. This definition could be regarded as inconsistent with Directive 97/68/EC, however not in light of the requirement of an on-board power source, but rather in the lack of specification as to what power-source is required. In this regard, Directive 97/68/EC requires an internal combustion engine be installed in the machine/equipment/vehicle, as specified in Annex I of the Directive. At present Directive 97/68/EC and its amendments only relate to various types of diesel fuelled engines as well as various types of spark ignited engines (petrol fuelled). Other types of power sources are not mentioned, and in this respect the RoHS definition is understood to be wider than the Directive 97/68/EC definition, as it does not exclude for example battery powered machinery. The request should thus be understood as one to amend and widen the scope of the RoHS NRMM definition to include machinery with an off-board power-source.

Concerning agricultural equipment, it has been suggested that such equipment may also benefit from the Exclusion in Article 2(4)(c). In this concern the RoHS FAQ document states:

“...The exclusion in Article 2(4)(c) applies to equipment that is specifically designed to be fitted into another piece of equipment that is itself excluded from scope.

Specifically designed EEE normally means that it is tailor made; it is designed to meet the need of a specific application. For example, for EEE to be specifically designed to a LSFI it needs to be designed, dimensioned and customised according to the need of the application.

For ‘specifically designed’ EEE to benefit from the exclusion of 2(4)(c) it must be intended only to be installed in another type of equipment that is excluded. Thus if a particular EEE can function in excluded and in scope equipment, it would be in scope unless it can be demonstrated (e.g. with sales documents, installation instructions, marketing literature, etc.) that it is only to be installed in an excluded equipment.”⁴¹

Thus, assuming that the agricultural machinery of relevance is indeed only manufactured for the purpose of being installed in other equipment excluded from scope, it would possibly benefit from this exclusion, regardless of its definition as NRMM with or without an on-board power source.

⁴¹ EU COM (2012), RoHS 2 FAQ Document, Q4.1, available under: http://ec.europa.eu/environment/waste/rohs_eee/pdf/faq.pdf

In contrast, where mobilised machinery is concerned, it seems that Directive 97/68/EC indeed may cover equipment which is mobilised between working locations and not only equipment mobile while working. This is interpreted through the reference in the Directive 97/68/EC NRMM definition to “transportable industrial equipment”, in which the mobility is understood to regard the possibility of moving such equipment from place to place. The RoHS NRMM definition, however does not seem to cover such equipment, as is understood from the Article 3(28) definition, stating “*the operation of which requires either **mobility** or **continuous or semi-continuous movement** between a succession of fixed working locations **while working***”.

It could be argued that such equipment may fall under the LSFI exclusion. The definition in Article 3(4) mentions that equipment is “intended to be used permanently in a pre-defined and dedicated location”. As mobile generation sets are installed on trailer trucks, to allow their mobilization, it could be interpreted that the equipment (the generation set) is used permanently in a predefined and dedicated location (the trailer truck). However, the FAQ Document clarifies that it was not the intention of the regulator for such equipment to be categorised as LSFI”Q.3.1 “...Machinery that has partial mobility, for example semi-mobile machinery running on rails, can be of ‘permanent use’. On the other hand, EEE that is intended to be used on different sites during its life is not considered as permanent. It is an indicator of permanent use if the equipment is not readily re-locatable (or ‘mobile intended’) and if it is intended for use at one single location...”

It is thus understood that though the various product groups may have been overlooked (in light of their similarities with excluded EEE) in both cases, it was not the original intention of the regulator for equipment from the mentioned product groups to be excluded from scope.

2.6 Critical Review

The on-set of this review is that the various product groups mentioned by stakeholders are in the scope of RoHS, whether intended by the regulator or not. Cord connected NRMM do not enjoy the current exclusion, as they do not have an on-board power source. Mobilised machinery operated at fixed locations also does not currently benefit from the NRMM exclusion, in light of its not being mobilised while working. Such equipment would also not benefit from the LSFI exclusion as explained above.

2.6.1 Difficulty of Compliance

Though stakeholders have mentioned different types of equipment in relation with the NRMM exclusion, a few similarities exist regarding the difficulties of such equipment to comply:

- To begin with, all product groups are said to be operated under conditions which pose higher reliability and safety requirements in comparison with consumer EEE: Machinery is explained to operate under harsh conditions, to be constantly exposed to debris and to vibration, while also being expected to have a relatively long service life (10-25 years, depending on product group). Products require more durability and reliability, in many cases also operating

in a wide range of climates (relevant for all machinery operated outside). These aspects mean that RoHS substance alternatives need to fulfil more stringent requirements as substitutes in comparison with, for example, consumer products with a short service life.

- All stakeholders have mentioned lead as a RoHS substance of particular concern. In engines, such as those of Gen-Sets, lead is present in engine bearings, in some electronic and cooling system components, and in some aluminium and copper alloys used in precision components such as housings, covers, connectors, and fittings. In NRMM equipment with an off-board power source, lead is anticipated in solder joints, printed circuit boards and other electrical components. For cleaning machinery, Cr VI could also be of concern, in light of the need for corrosion resistance where heavy duty cleaning materials are used, as well as cadmium and lead used as stabilisers in cables. All stakeholders explain that substitutes are currently not available, with research and testing of possible alternatives needing more time to validate that their use in the various product groups will provide comparable performance and reliability.
- In all cases, stakeholders have demonstrated that there exists similar types of equipment which are not in the scope of RoHS. In this sense, part of the argumentation of all contributors regards the **cost of compliance for similar equipment not in scope**, which may be impacted in light of the manufacture of components on the same production lines. For electronic components, compliance may be brought about in some cases through pressure from other markets of suppliers to be RoHS compliant (in many cases the manufacturers of equipment do not have sufficient power to influence suppliers). However, the compliance of non-electronic parts is said to be a possible source for heavy compliance costs.

In the case of NRMM with off-board power sources, it is further understood that equipment is usually manufactured in small quantities, further supporting that any changes in the design could affect all similar models. In cleaning machinery *“aside from the power supply the machines shall be almost identical... above 95% of components are exactly the same and are manufactured on the same production line”*. Furthermore *“most manufacturers are assumed to be close in size to SMEs or possibly slightly larger”*.⁴² As for agricultural equipment, *“the volume of sales for such products, for a specific model, this can range from 1 per year up to several hundred per type but no more”*⁴³. Similarly, regarding construction and mining equipment, *“the total sales of each individual product is relatively low globally. For products that are available both with an on-board or with an electric [external] power source, the customer has the option of selecting which model is preferred for its mine... the share of electric machines varies widely from year to year. For the most part, however, many of the mining products are available only in electric versions, but these non-*

⁴² Op. cit. EUnited Cleaning (2914c)

⁴³ Op. cit. CEMA (2014b)

road electric powered mobile machines use many of the same components as the diesel and gas powered electric machines".⁴⁴It is thus understood that though compliance may be possible with time, this could require significant resources for researching possible alternatives and testing their reliability. In some of the mentioned cases, the product groups have a very wide range of different products, manufactured in relatively small quantities (between 1 and 100 per year). In such cases a further burden of compliance will be needed to ensure compliance for each and every model of a wide product portfolio, both from a technical perspective as well as from the administrative perspective of documenting compliance. In other cases the fact that most equipment is out of scope with a small share of equipment being in scope (20% and less) shall impact the burden of compliance, particularly in cases where the compliance of equipment which is out of scope is "forced", in light of mutual production lines

The costs of compliance are thus understood to be relatively high, especially where machinery is manufactured in small volumes per model.

2.6.2 Impact Review of the Various Product Groups

Since each of the product groups mentioned by the various stakeholders exhibits slight differences in various aspects, a short review of the main aspects for each is provided below, as well as conclusions and recommendations as to the possible courses of action.

Cleaning Machinery

In terms of **Environmental Impacts**, if cleaning machinery with an off-board power source is to remain in scope, environmental benefits could be expected, related to applications in which RoHS substances are to be replaced with time. Eunited Cleaning mention that RoHS substances are present in various components in negligible concentrations. However, this is understood to be in relation to the machine weight and not in relation to the homogenous material. Exact quantities are not provided, however for most of the applications mentioned, from the experience of the consultants', it can be followed that RoHS substances presence would be small in terms of the weight per machine (e.g. Pb in lead based solders; Cr VI in corrosion protection of metal parts). In light of the conditions of use of machinery it is expected that finding alternatives with comparable performance and reliability may be challenging (e.g. exposure to vibrations; exposure to changing weather conditions and road salts; exposure to acid or alkaline cleaning agents; design intended for long-life). Though this can be supported by exemptions currently available for other mobile equipment operating under similar conditions, e.g. Ex. 33⁴⁵, it is apparent that

⁴⁴ Op. cit. CECE (2014a)

⁴⁵ Quoted from Directive 2011/65/EU, Annex IV: Ex. 33: "Lead in solders on populated printed circuit boards used in Directive 93/42/EEC class IIa and IIb mobile medical devices other than portable emergency defibrillators. Expires on 30 June 2016 for class IIa and on 31 December 2020 for class IIb" This exemption is available for medical devices with long service lives, exposed among others to

substitutes may become available for some applications within the coming few years. It is thus assumed that such devices could become RoHS compliant through the development of substitutes, or where this would require additional time (post 2019), by requesting exemptions, until the reliability of possible alternatives could be proven.

EUnited Cleaning have further attested that manufacturers have little influence over their suppliers, where the use of RoHS substances in components is concerned; Though this may hinder their influence on the RoHS compliance of supplies, where alternatives are developed for other EEE manufacturers with larger market shares, these could with time lead to the phase-out of RoHS substances in cleaning machinery supplies as well.

It is thus understood that environmental benefits are expected connected to the phase-out of RoHS substances. However, in light of the cleaning machinery industries market share, it can also be followed that compliance shall depend on development of substitutes for other EEE, possibly requiring more time where reliability of alternatives is not proven. As it can be followed that the amount of RoHS substances in use is rather small in relation to machine weight, and as only 20% of cleaning machinery are said to be in scope, it is concluded that benefits would be small. Furthermore, the distribution of benefits could vary over time between the mid-term and the long term (5 to 10 years and above), with benefits expected at least in part, regardless of the equipment being in scope or not.

As for **Economic Impacts**, EUnited Cleaning expect costs of compliance to be high in light of the possible impacts of alternatives on reliability and the large development effort needed to make substitutes available.⁴⁶ It seems that these could be quite large in relation to the benefits expected. The cleaning machinery sector is said to be highly specialised and extremely export-oriented, with the European turnover amounting to 1.5 billion €. ⁴⁷ Only part of this is understood to be relevant for equipment which is in scope, as it has been stated that only 20% of the product range is in the scope of RoHS (off-board power source), amounting to 14,000 units placed on the market per annum. Furthermore, it is said that most manufacturers are SMEs or slightly larger than SMEs, with all manufacturers producing both models that are in and out of scope (off-board and on-board power source respectively). On this basis it can be followed that efforts towards RoHS compliance could create a large burden for this industry, especially where substitution is to require resources for research and development as well as for reliability testing over a longer period of time. Since the main market share of these companies is in the manufacture of machinery with on-board power sources, manufacturers could pull cord-powered models off the EU

strong mechanical strains such as vibrations during operation. As is clear from the exemption duration, substitutes are expected in some cases as early as 2016 and in others in 2020.

⁴⁶ Op. cit. EUnited Cleaning (2014b)

⁴⁷ See <http://www.eu-nited.net/cleaning/commercial-cleaning-industrial-cleaning-commercial-cleaning-indu/index.html>; EUnited Cleaning represents the leading producers of floor cleaning machines and high pressure cleaners for commercial and industrial use. It is thus assumed that these figures represent cleaning machinery for commercial and industrial use, i.e. for professional use, and do not reflect the turnover of consumer products.

market to avoid the need for compliance. This would impact (professional) consumers, in terms of loss of availability of part of the current product range. In light of the reasons stated for using cord-powered models (see Section 2.4.2), this would result in higher prices (costs) for consumers as well as a loss of effectiveness in operation where recharging needs create a loss of working time. Changes to market structure are not expected as all manufacturers produce both types of models in light of the similarity of both on and off-board powered equipment; all manufacturers are expected to be affected by RoHS similarly, regardless of types of machinery that they produce or the location of manufacturing sites (inside or outside EU). Though the impacts shall be similar, larger manufacturers may be able to cope slightly more easily with this burden in comparison with smaller manufacturers, which are understood to be more dominant in this industry. To conclude, costs are to be expected and could be substantial in light of:

- the efforts needed to support compliance;
- the related turnover of the relevant machinery; and
- the size of manufacturers.

If such costs are to be severe, manufacturers could phase-out of cord-powered models, shifting costs to consumers. A shift back could occur with time, if substitutes are to be found for similar applications of other product groups in scope.

Regarding **Social Impacts**, where a shift to battery operated machinery is to occur, in heavier models, operation convenience would be affected to some degree, though it is understood that this is only relevant in a few models. The need to recharge machinery from time to time may also make operation less convenient and consequently more expensive for the users of such equipment, needing more time to complete the a certain task. Both of these could be perceived as impacts on employment, though it is not expected that employees shall need other skills or are to experience a change in job opportunities. In terms of impacts on health, positive impacts are only to be expected in relation with the phase-out of RoHS substances. Such impacts are expected to be small or negligible in light of proportionality to environmental benefits and since emissions are not expected in relation to use, while expected to be controlled and contained during other life cycle stages. Negative impacts could be expected if substitution of Cr VI were to decrease the reliability of machinery in terms of corrosion protection where heavy duty cleaning materials are used. In cases where leaks or emissions of heavy duty cleaning materials occur during use this could result in impacts on operators and observers. Such impacts however are not expected as it is to be expected that an exemption would be requested for substitutes of lesser reliability, especially where this could result in impacts on environment or health.

All in all it is expected that costs of compliance may prove to be higher than the possible benefits thereof. Though information is not sufficient to make a quantitative comparison, it seems that costs are significantly higher, with environmental benefits expected in part, regardless of whether cord-powered equipment remains in scope or not. If the Commission can follow that such costs are higher than the expected benefits therefor, an amendment of Article 3(28) could be considered. In this regard, Eunited Cleaning have proposed to add “or with a traction-drive” to the current

formulation, to ensure that the change does not broaden the scope of this exclusion beyond their needs.

The consultants would like to note that the Commission should consider any changes while keeping in mind what the purpose of the limitation of the RoHS exclusion to equipment with an on-board power source was in the first place. If the purpose was alignment of RoHS 2 with the NRMM definition of Directive 97/68/EC, this would mean that professional cleaning equipment was not meant to benefit from this exclusion to begin with; Models with an on-board power source are equipped with a battery and do not use a combustion engine or a spark ignition engine as required in Directive 97/68/EC. Nonetheless, changing the formulation of Article 3(28) to clarify that all such machinery would be in scope, would be perceived as an act of legal inconsistency in light of its retroactive character and would also not be recommended.

Agricultural Machinery

In terms of **Environmental Impacts**, it is unclear how common the use of RoHS Substances is in agricultural machinery, as this product group was previously excluded from RoHS and a thorough analysis is yet to be performed. Where substances are in use, CEMA⁴⁸ explain that *“Given the small volumes and the fact that our industry are followers, specific components for our sector would never be developed by suppliers”*. It is thus concluded that where relevant, the phase-out of RoHS substances shall depend on their phase-out in other regulated equipment. Where components are manufactured by suppliers serving other EEE manufacturers, phase-in may occur regardless of if agricultural equipment remains in scope or not. In contrast, where components are produced by suppliers who do not serve other manufacturers of EEE (or manufacturers of equipment regulated under ELV which has similar restrictions), phase-out shall require time and shall mainly burden manufacturers of agricultural machinery.

In terms of **Economic Impacts**, the lack of data concerning RoHS substances makes an estimation of costs difficult. As stated above, it is clear that in some cases phase-out shall occur in light of compliance of other sectors. Here costs could be less significant, as they would be carried and shared with other sectors. In other areas, for example non-electrical components, where the agricultural machinery sector is to carry the main burden of compliance, costs could be significant if RoHS substances are used in applications for which substitutes are not available or do not provide comparable performance and reliability. To add to this, the product portfolio is understood to be very wide, with the sales of most models ranging from 1 to less than 100 devices per annum. This would mean that as compliance will need to be ensured for each and every model, that the cost could be significant in light of the low volume of production of various models. It is understood that taking products off the market

⁴⁸ Op. cit. CEMA (2014b)

is not plausible scenario in light of customer preferences⁴⁹, meaning that any costs of compliance would burden manufacturers, consequently set-off through higher prices for (professional) consumers.

It is difficult to estimate **Social Impacts** in light of the lacking information concerning the use of RoHS substances. Possible positive impacts would be related to the range of impacts expected in relation to the use of RoHS substances and their possible phase-out. If the availability of agricultural machinery is to be affected, or the price to agricultural consumers, this could impact employment or lead to social impacts where additional costs are to be passed on to consumers of agricultural produce.

The lack of information as to the actual use of RoHS substances in agricultural machinery and their range of application makes further conclusion as to the range of costs and benefits difficult. Possible phase-out of RoHS substances shall depend on the applications in which such substances are used and the existence of similar applications in other EEE (or in ELV regulated vehicles). Without understanding what applications are of relevance, it is difficult to conclude if substitutes candidates exist and how much time and resources are to be needed for their implementation in this sector. It is understood that only agricultural machinery which is not self-propelled may be in the scope of RoHS. Such equipment is further understood to always be towed by another vehicle, e.g. a tractor or a vehicle which would be exempt through Article 2(4)(f)⁵⁰. Art. 2(4)(c) excludes “*equipment, which is specifically designed, and is to be installed, as part of another type of equipment that is excluded or does not fall within the scope of this Directive, which can fulfil its function only if it is part of that equipment, and which can be replaced only by the same specifically designed equipment;*”. Agricultural machinery which must be towed to perform its purpose is understood to be designed as an interchangeable part of another type of equipment (vehicle) which is out of scope. It is further understood that such machinery would not be able to fulfil its function if it were not to be towed by such a vehicle, as it would lose its mobility which is necessary for its function. Agricultural machinery, which is not self-propelled, is further understood to receive any needed power from the towing vehicle, also making such machinery dependant on such vehicles. Aside from the term “installation”, such machinery adheres to the various conditions stipulated in Article 2(4)(c), and could benefit from this exclusion, if the interchangeable connection between agricultural machinery and the towing vehicle were clarified to fall under this term. The consultants recommend that the Commission clarify what is meant in this article by the term “installation”. This would allow certainty as to if agricultural machinery which is not self-propelled is in scope or not.

⁴⁹ CEMA (2014b) explain that „Given that there is a big difference between self-propelled (with power source) and towed (without power source) machines in customers/price and that therefore there is a market for both of them, taken products off the market is not an option. There are no alternatives.“

⁵⁰ Article 2(4)(f) excludes: “means of transport for persons or goods, excluding electric two-wheel vehicles which are not type approved”

Mining Machinery

CECE⁵¹ provide examples of electric powered non-road mobile machinery used primarily in mining, explaining that it is practically identical to diesel powered (or gas powered) NRMM in every other respect. Some of the detailed examples are understood to benefit from various exemptions such as “the means of transportation” exemption (Article 2(4)(f)) or products having both a diesel drive train and a trailing cable supplying power when drilling⁵². It is however also understood that some models do not have an on-board power source, meaning that here too; equipment is in the scope of RoHS and is required to comply with the substance restrictions.

Concerning possible presence of RoHS substances, it is explained that a general analysis has not been performed. Lead in solders is mentioned as a possible example of applications using RoHS substances, however aside from this example, it could not be said if RoHS substances are to be expected in equipment and at what range. Assuming such substances are present, their possible phase-out would create environmental benefits, however it is difficult to say what the range of such benefits would be. Since CECE explain that electric powered NRM mining machinery is understood to have a small EU market share⁵³, though Environmental Impacts could be expected where RoHS substances are to be phased out, it could be that absolute benefits would be small in light of the market share of equipment placed on the EU market.

In parallel, a small market share of electric powered NRM mining machinery could also mean that the market share is too small for manufacturers to be willing to carry the burden of RoHS compliance. This could further be supported by the harsh conditions under which such equipment is operated. As with other EEE, such conditions of use often require that available alternatives be tested and further developed before they can be applied as substitutes in equipment, requiring manufacturers to invest resources and time in compliance. In cases where the burden of compliance is small (alternatives used by other sectors can be easily adapted), they may be applied, possibly in both excluded and non-excluded equipment. This would mean that benefits are larger than expected as they are related to a larger range of equipment than the machinery regulated under RoHS. However, in cases where the burden of compliance is to be high, non-compliant equipment may be pulled off the EU market, leading to negative **Economic Impacts** for consumers (the mining industry) in light of a loss of product range. It is thus expected that either the mining machinery sector shall have small costs or that non-compliant machinery is to be pulled of the market, both creating a loss in income for mining machinery manufacturers as well for their clients – the mining industry – and those using mined resources.

⁵¹ Op. cit. CECE (2014a)

⁵² Article 3(28) does not specify that the on-board power source must be operated while the equipment is working but only that the equipment must be mobile while working

⁵³ Op. cit. CECE (2014a)

CECE did not mention potential social impacts, though the range of these shall be related to the various impacts mentioned above: Where RoHS substances are to be phase-out, some positive health impacts may be expected if this is to lead to lower emissions through the equipment life cycle. Where manufacturers are to be impacted, this may have subsequent impacts on employment. If less equipment is to be manufactured, this could have a negative impact on employment in the mining machinery sector, possibly also impacting employment in the mining industry. If however manufacture is mainly impacted in light of the research and development of RoHS substitutes, this could create employment opportunities related to R&D.

In lack of detailed information and data it is difficult to estimate the range of possible costs and benefits related to NRM mining machinery remaining in scope. In this sense concluding as to the net benefit and the relevance of excluding such equipment is not possible. However, in light of the similarities between equipment which is in scope and out-of scope, it can be followed that the need to comply with RoHS may create a burden for manufacture of equipment which is not in the scope of RoHS. This case is understood to be similar to that of cleaning equipment, with the additional justification that equipment, which is not in scope of RoHS would have a combustion engine and thus fall under the Directive 97/68/EC NRMM definition. It can thus be followed that manufacturers see inconsistencies in how NRMM is regulated under these two Directives.

To conclude, the case of NRM mining machinery may be resolved indirectly if the “off-board power source” aspect raised for cleaning machinery is to be resolved. Otherwise, the consultants would recommend the EU COM to consider adding an exclusion for mining equipment in the next recast of the Directive, possibly after additional information has been made available to clarify the relation between possible costs and benefits of compliance. An important question in this respect is if a shift from off-board to on-board power source mining machinery could impact the range of mining activity emissions, and how such impacts would relate to possible environmental benefits of such equipment being regulated under RoHS.

Generation Sets⁵⁴

In terms of **Environmental Impacts** it is understood that lead is the primary RoHS substance of concern in Gen-Sets. As explained in Section 2.4.3, EUROPGEN have estimated that approximately 1500 kg of lead could be placed on the EU Market through the sales of example products, explaining this to be a conservative estimation. This amount of lead could potentially be phased-out where alternatives are found and developed into reliable substitutes. This is thus understood to be the basis for estimating possible environmental benefits and their range. Where lead is to be phased out, any impacts connected with possible emissions during the various life cycle phases would decrease. Though the range of possible benefits (a decrease in the amount of Pb applied in GENSETs and placed on the EU market) is clear, the time

⁵⁴ NAM (2014a) have also mentioned petroleum extraction equipment and industrial power systems in their contribution as applications where combustion engines may be in use

needed for these benefits to incur is more difficult to estimate; EUROMOT⁵⁵ has explained in the past that although members have stated their intention to comply by the end of the transitional period [2019], present indications are that some products may not be capable of complying.⁵⁶ This means that even if some of these benefits could be expected to incur before 2019, in areas where substitutes are not yet suitable for use in GENSETs benefits could incur over a longer period.

Equipment with an internal combustion engine, such as GENSETs has been discussed in part in a scope review prepared by Oeko-Institute in 2014⁵⁷. At the time it was assumed that, where substitution would be possible, it could be achieved for a larger range of equipment than that falling in scope, meaning that compliance of RoHS regulated GENSETs may “force” partial compliance of non-regulated ones. It is unclear if this is indeed the case; however, this creates a relation between possible environmental benefits and possible **Economic Impacts**. It has been explained that LSFIs GENSETs and mobilised GENSETs are in principal identical, with the only differences related to the existence or non-existing of a transporting vehicle on which mobilised GENSETs are mounted. It is thus assumed that such GENSETs will be manufactured on the same production lines. Thus, where substitutes are to require a change in the design of Gen-Sets, they could be expected to be applied to a wider product range. If the costs of such changes were to be so high as propose a threat to the stability of this industry, manufacturers would either seek exemptions (benefits to remain in range) or discontinue the manufacture of mobilised GENSETs (resulting in costs for consumers in terms of loss of product range). As the development of substitutes is application specific, it is difficult to estimate on the basis of the present information, what the range of total benefits would be and how much time full compliance would require. None the less, it is understood that any impacts should affect manufacturers similarly; EUROPGEN estimates that the RoHS restrictions on temporary, non-stationary generating sets will have an impact throughout the power generation industry and also throughout the engine manufacturers. ⁵⁸

Estimating Social Impacts is difficult. Where manufacturers or suppliers of components are to be impacted by the need to comply with the RoHS restrictions, this could impact employment: If manufacture and sales of certain mobilised GENSETs for the EU market is to be discontinued or reduced, this could result in a decrease in employment. If this however results in larger sales of LSFIs GENSETs, such impacts would decrease or lose relevance. In parallel, where research into substitutes and

⁵⁵ EUROMOT (2014a), EUROMOT contribution to the RoHS Stakeholders consultation concerning the Article 2(2) Scope Review, submitted 7.3.2014 per email, available under: http://rohs.exemptions.oeko.info/fileadmin/user_upload/RoHS_IA_2_2/Products_newly_in_scope/20140307_EUROMOT_RoHS_2_Oeko-Institut_Review_EEE_newly_in_Scope-Questionnaire_Final_Response_2014-03-07.pdf

⁵⁶ Op. cit. EUROMOT (2014a)

⁵⁷ See Report under: http://rohs.exemptions.oeko.info/fileadmin/user_upload/reports/201406012_RoHS_Scope_Review_report_final.pdf

⁵⁸ Op. cit. EUROPGEN (2014a)

redesign are to be needed, this shall have a positive influence on R&D employment in this sector. Impacts on health are to be related to the possible phase-out from lead. Though this may reduce any possible emissions, most emissions can be expected in the manufacturing and/or end-of-life phase, where it is assumed that they are at least partially controlled. Thus any such benefits would probably be small in range or possibly even negligible.

Despite a potential for environmental and health benefits, it seems there is a high risk that compliance of mobilised GENSETs could force compliance of LSFI GENSETs, resulting in high economic burdens affecting a sector understood to mostly manufacture equipment which is not in scope. The mobility of such equipment is understood to be different from that of NRMM covered in the RoHS Article 3(28) definition, as equipment is not operated while working. Without a change of this definition, such equipment could not benefit from the NRMM exclusion.

Examining the case of mobilised GENSETs solely within the RoHS 2 context suggests that they neither fall under the NRMM nor under the LSFI exclusions. This understanding would suggest that this case does not fall under the mandate of the consultants' in this review. However, it is understood that the RoHS definition of NRMM differs from the definition provided in Directive 97/68/EC, which also refers to "transportable industrial equipment", interpreted to cover mobilised Gen-Sets. In light of this inconsistency coupled with the risk of possible economic burdens for a sector understood to mostly manufacture equipment which is not in scope, the consultants recommend revising the NRMM definition to ensure that all equipment covered by Directive 97/68/EC would also be defined as NRMM under RoHS 2, thus benefiting from the NRMM exclusion.

It should further be mentioned that NAM (2014a) has also mentioned petroleum extraction equipment and industrial power systems in their contribution as applications where combustion engines are in use in equipment which is not mobile while working. Though the details of this equipment may be slightly different from Gen-Sets, it is understood that in both cases such equipment would fall under the Directive 97/68/EC NRMM definition and not under the RoHS NRMM definition. In this sense, the above recommendation is understood to also resolve this case.

2.6.3 Conclusions and Recommendations

To summarise, the consultants can follow that the NRMM Directive (97/68/EC) and the RoHS Directive regard non-road mobile machinery inconsistently. Under RoHS the type of power source of such machinery is irrelevant, as long as the power source is on-board. The NRMM Directive on the other hand only regulates such equipment in which an integral combustion engine is installed. Though the understood intention of the NRMM Directive, to prevent emissions of such machinery, may explain why other power sources are not mentioned, it is clear that the scope of NRMM is interpreted differently in each Directive. In all the product groups discussed in this review, the various inconsistencies create problems in terms of similar equipment in some cases being in scope and in some cases being excluded. Stakeholders raise concerns that the burden of compliance of NRMM which is in scope shall be high in relation to expected benefits thereof, particularly in cases where most equipment is excluded. It is also understood that compliance of equipment which is in scope may force

compliance of equipment which is excluded, in light of mutual production lines. This would mean that manufacturers of equipment not in the scope of the RoHS Directive are faced with compliance costs despite such equipment not needing to comply with the Directive.

The various product groups have been discussed in the sections above, to clarify how equipment may be affected and what costs and benefits the enforcement of the current RoHS Directive may result in for NRMM manufacturers. The main conclusions and recommendations are as follows:

For **professional cleaning NRMM** the costs of compliance may prove to be higher than the possible benefits thereof. It seems that compliance costs shall be high, with environmental benefits expected in part, regardless of whether cord-powered equipment remains in scope or not. If the Commission can follow that such costs are higher than the expected benefits therefor, an amendment of Article 3(28) could be considered. A possible amendment could be to add “or with a traction-drive” to the current formulation, to avoid unnecessary broadening of the scope of the exclusion.

Regarding **agricultural machinery**, it is understood that only agricultural machinery which is not self-propelled may be in the scope of RoHS. Such equipment was explained to always be towed by another vehicle, e.g. a tractor or a vehicle, which is itself excluded as a means of transport for persons or goods through Article 2(4)(f). Agricultural machinery which must be towed to perform its purpose is understood to be designed as an interchangeable part of another type of equipment (vehicle) which is out of scope. Such machinery would not be able to fulfil its function if it were not to be towed by other vehicles, as it would lose mobility and would also lose its power source. Aside from the term “installation”, such machinery adheres to the various conditions stipulated in Article 2(4)(c), and could benefit from this exclusion, if the interchangeable connection between agricultural machinery and the towing vehicle were clarified to fall under this term. The consultants recommend that the Commission clarify what is meant in this article by the term “installation”, as this would allow certainty as to if agricultural machinery which is not self-propelled is in scope or not.

Regarding **mining machinery** detailed information was not available to allow estimating the range of possible costs and benefits related to NRM mining machinery remaining in the scope of RoHS. The key issue for such equipment with the current interpretation of NRMM is for mining machinery with an off-board power source. In light of the similarities between equipment which is in scope and out-of scope, it can be followed that the need to comply with RoHS may create a burden for manufacturers of equipment. The harsh conditions of use of this machinery are explained to make the search and implementation of possible substitutes difficult and lengthy, probably resulting in high costs for compliance. In parallel, it is uncertain how successful this search may be and how much time shall be needed before benefits could incur. Adjusting the off-board power source aspect in the RoHS definition of NRMM (as may be found relevant for other equipment groups reviewed in this report), could resolve compliance issues of manufacturers of mining machinery which is in scope indirectly. If such an adjustment is decided against, it is recommended that the EU Commission review the impacts of excluding mining equipment from the scope of RoHS, once more detailed information is made available

to allow understanding the potential range for costs and benefits of remaining in the scope of RoHS.

As for **mobilised machinery operated at fixed locations**, despite a potential for environmental and health benefits, it seems there is a high risk that compliance of mobilised GENSETs could force compliance of LSFI Gen-Sets. This could result in high economic burdens affecting a sector understood to mostly manufacture equipment which is not in scope. The mobility of such equipment is understood to be different from that of NRMM covered in the RoHS Article 3(28) definition, as equipment is not operated while working. Without a change of this definition, such equipment could not benefit from the NRMM exclusion, despite the understanding that it falls under the NRMM definition of Directive 97/68/EC. In light of this inconsistency, coupled with the risk of possible economic burdens for a sector understood to mostly manufacture equipment which is not in scope, the consultants recommend revising the RoHS NRMM definition to ensure that all equipment covered by Directive 97/68/EC would also be defined as NRMM under RoHS 2, thus benefiting from the NRMM exclusion.

Furthermore, the consultants recommend that any changes to be considered by the Commission, be decided upon while keeping in mind the intended purpose of the limitation of the RoHS NRMM exclusion to equipment with an on-board power source. If the intention of this limitation was alignment with the NRMM Directive, achieving this purpose should guide any possible decisions as to adjustments of the Directive.

2.7 References

| | |
|--------------------------|--|
| CECE (2014a) | CECE (2014a), CECE Answers to NRMM Questionnaire, submitted per email on 05.12.2014 |
| CEMA (2014a) | CEMA (2014a), Personal communication titled "CEMA request - related to the analysis of impacts from RoHS 2 on various products: non-road mobile machinery without an on-board power source", sent per email on 7.10.2104. |
| CEMA (2014b) | CEMA (2014b), CEMA Answers to NRMM Questionnaire, submitted per email on 03.12.2014. |
| EU COM (2012) | European Commission (2012), RoHS 2 FAQ Document, Q4.1, available under: http://ec.europa.eu/environment/waste/rohs_eee/pdf/faq.pdf |
| EUnited Cleaning (2014a) | EUnited Cleaning (2014a), EUnited Cleaning Letter to European Commission Concerning time frame Restriction of Hazardous Substances (RoHS, Directive 2011/65/EU) , submitted per email on 5.3.2014 |
| EUnited Cleaning (2014b) | EUnited Cleaning (2014b), EUnited Cleaning Answers to NRMM Questionnaire, submitted per email on 28.11.2014 |
| EUnited Cleaning (2014c) | EUnited Cleaning (2014c), Summary of telephone conference with Charalambos Freed and Axel Leschtar, held 4.12.2014 |
| EUnited Cleaning (2014d) | EUnited Cleaning (2014d), Letter with Request/Comments Concerning RoHS 2, Definitions, sent per email on 8.12.2014 |
| EUROMOT (2014a) | EUROMOT (2014a), EUROMOT contribution to the RoHS Stakeholders consultation concerning the Article 2(2) Scope Review, submitted 7.3.2014 per email, available under: http://rohs.exemptions.oeko.info/fileadmin/user_upload/RoHS_IA_2_2/Products_newly_in_scope/20140307_EUROMOT_RoHS_2_Oeko-Institut_Review_EEE_newly_in_Scope-Questionnaire_Final_Response_2014-03-07.pdf |
| EUROMOT (2014b) | EUROMOT (2014b), EUROMOT Answers to NRMM Questionnaire, submitted per email on 2.12.2014 |
| EUROPGEN (2014a) | EUROPGEN (2014a), EUROPGEN Answers to NRMM Questionnaire, submitted per email on 2.12.2014 |
| NAM (2014a) | NAM (2014a), NAM Answers to NRMM Questionnaire, submitted per email on 2.12.2014 |

3.0 Windows and Doors with Electric Functions

3.1 Abbreviations

| | |
|--------|---|
| EEE | Electrical and electronic equipment |
| Cr VI | Hexavalent chromium |
| OEM | Original Equipment Manufacturer |
| LSFI | Large Scale Fixed Installation |
| POP | Persistent Organic Pollutant |
| RoHS 2 | Directive 2011/65/EU |
| SME | Small and Medium Enterprises |
| WEEE | Waste Electrical and Electronic Equipment |

3.2 Introduction

With the coming into force of RoHS 2, an open scope has been adopted concerning products that need to comply with the substance restrictions as well as with other administrative obligations. To accommodate this change, the new Category 11 was added to Annex I of the Directive, which lists the relevant product categories that are in scope. Category 11 is specified as “Other EEE not covered by any of the categories listed above”. Windows and doors with electric functions are understood to fall to some extent within the scope of RoHS 2 under category 11 and will have to comply from 22 July 2019.

As until recently, industry is understood to have not been fully aware of the compliance requirement for this sector, this product group had not been fully assessed in the 2011 BIOIS study for the Commission.⁵⁹ The Commission has thus found it necessary to perform a review of the impacts of RoHS 2 on windows and doors with electric functions, to understand the scope of the problem and possible options for resolving it, possibly through exemptions.

This study has thus attempted to quantify the share of products affected and to assess manufacturers' technical or procedural problems with RoHS compliance for windows and doors with electric functions. Analysis was also aimed at understanding where in the product and in the supply chain the problems can be located and tackled.

⁵⁹ BIOIS & ERA (2012), BIO Intelligence Service and ERA Technology (2012): Measures to be implemented and additional impact assessment with regard to scope changes, pursuant to the new RoHS Directive, Final Report prepared for the European Commission, DG ENV, Retrieved from: http://rohs.biois.com/documents/RoHS_II_IA_Final_Report.pdf

Automatic doors and gates Factsheet, retrieved from: <http://rohs.biois.com/product-group-factsheets>

3.3 Background of Review

In 2011–2012, BIOIS carried out a study for the European Commission in which, inter alia, impacts for various product groups newly included in the scope of RoHS were investigated to clarify the potential for costs and benefits of this inclusion. Automatic doors and gates were one of the product groups investigated in this context. The BIOIS study report⁶⁰ concluded that the (environmental, economic, and social) impacts are limited because the assessed product groups are not characterised by particularly large market volumes and significant occurrences of RoHS substances, commenting that very limited data were available. The report recommended no change to the present status.

However in 2014 stakeholders raised concern as to the range of impacts expected, should these product groups remain in the scope of RoHS. The main claims being in light of the understanding that compliance of windows and doors shall affect the manufacture of all articles, regardless of their being equipped with electrical components. As most manufactures were explained to be SMEs, this was expected to be a burden which would have adverse impacts on the windows and doors manufacturing sector. The EU COM thus commissioned a further study (resulting in this report), with the aim of quantifying the scope and nature of the problem and identifying possible solutions.

In the course of this project, registered stakeholders of the RoHS evaluation website were notified of the review and the possibility in providing information. EuroWindow⁶¹ was contacted directly in light of prior communication with the EU COM concerning the possible impacts should windows and doors remain in the scope of RoHS and provided written information. An attempt was made to contact additional stakeholders; however this did not result in the provision of additional information.

3.4 Product Group Description and Background

Windows and doors are defined as construction products according to Article 2(1) of the Construction Product Regulation (CPR)⁶²: ‘construction product’ means any product or kit⁶³, which is produced and placed on the market for incorporation in a permanent manner in construction works or parts thereof.

In a JRC-IPTS document about Green Public Procurement of windows and external doors, a window is defined as a building component (glazing) for closing an opening in

⁶⁰ Opt cit. Bio IS (2012)

⁶¹ EuroWindow is the umbrella organization of four European associations of fenestration and door sector and 30 national federations in Europe; <http://www.eurowindow.eu/eurowindow.html>

⁶² Construction Product Regulation (CPR): Regulation (EU) No 305/2011 laying down harmonised conditions for the marketing of construction products and repealing Council Directive 89/106/EEC; <http://eur-lex.europa.eu/legal-content/EN/TXT/PDF/?uri=CELEX:32011R0305&from=en>

⁶³ ‘Kit’ means a construction product placed on the market by a single manufacturer as a set of at least two separate components that need to be put together to be incorporated in the construction works.

a wall or pitched roof that will admit light and may provide ventilation, including the frame of the window, which is defined as the component forming the perimeter of a window, enabling it to be fixed to the structure. A roof window is explained to be intended for installation in a roof or the like, which is inclined, and will have the same characteristics as windows installed in walls with regard to function, cleaning, maintenance and durability.⁶⁴

The Oxford Dictionary defines a door as a hinged, sliding, or revolving barrier at the entrance to a building or a room.⁶⁵ According to JRC-IPTS (2012) a door includes the frame of the door, enabling it to be fixed to the structure. The main intended use is the passage of pedestrians;⁶⁶ however automatic doors or gates may also be used as garage doors allowing the passage of cars or lorries.

Manufacturers have started looking into the integration of various electrical components into these articles as a means of supporting and/or extending the functionality of windows and doors. This has brought about an abundance of electric components and functions that can be installed to operate with these articles such as:⁶⁷

- Sensors for monitoring locking functions and/or safe and vault status, such as glass break detectors that are connected to alarm systems;
- Electrical locking systems: Sensors linked to a motor driven closing system, connected to ventilation and climate control systems;
- Electromotive actuation of windows and doors for automatic opening:
 - Windows with automatic control are used for e.g. natural ventilation where windows are hard to reach or for automatic smoke control;
 - Automatic doors are linked to sensors (movement and open/close sensors) and can be used for various purposes, providing benefits in terms of energy savings, comfort, accessibility, access control systems, fire protection etc.;

⁶⁴ JRC-IPTS (2012), Joint Research Centre's Institute for Prospective Technological Studies (JRC-IPTS) (2012): Green Public Procurement Windows and External Doors – DRAFT, Technical Background Report; Report for the European Commission – DG-Environment, 2012; <http://susproc.jrc.ec.europa.eu/windoors/docs/Technical%20background.pdf>

⁶⁵ <http://www.oxforddictionaries.com/definition/english/door>

⁶⁶ Op. cit. JRC-IPTS (2012)

⁶⁷ VFF (2013) basically lists electric components; the following bullet points however summarize the electric components with regard to their intended function.

VFF (2013), Verband Fenster + Fassade (VFF), Merkblatt KB.02: Elektrische Bauteile im Fenster-, Türen- und Fassadenbau, Planung und Ausführung, September 2013; Verband Fenster + Fassade in Zusammenarbeit mit dem Zentralverband der Elektroindustrie (ZVEI), Institut für Fenstertechnik, Rosenheim.

See the table of contents of VFF (2013) at:

http://www.window.de/fileadmin/redaktion_window/vff/Shop_pdfs/KB_02_1309_Inhalt.pdf

- Automatic roller shutters for heat and sun protection or darkening/dimming systems also provide energy savings (these are not always an integrated part of the window);
- Air conditioning components.

The electric function is usually a very small part of the total product in terms of both weight and volume: According to EuroWindowor in a door with electronic lock the electronic component makes up 1 % by weight; in another example such as a roof window, the electronic component for automatic control makes up 3% by weight.⁶⁸ Magnet sensors for instance are a very small part within the frame, in comparison to the size or the weight of the door or window.⁶⁹ The following figure indicates that the electrical components are mostly located in the frame.

Figure 3-1: Indication where the Electric Components are Located in the Windows and Doors (indicative list, from VFF 2013)

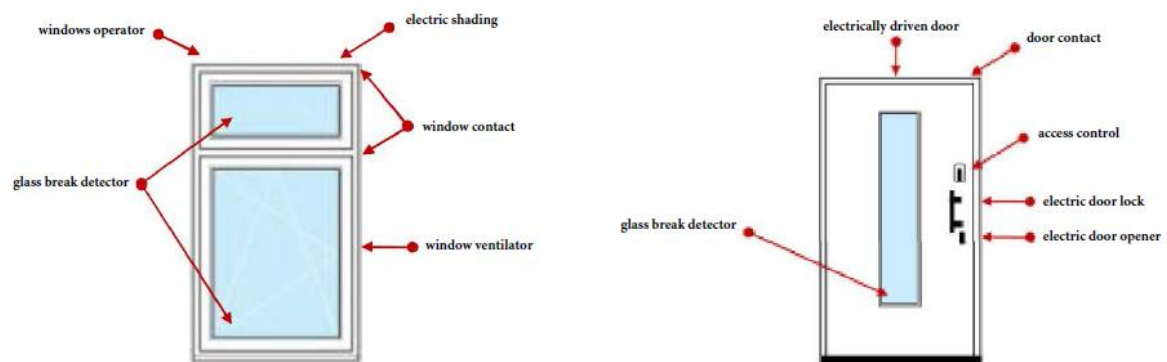

Source: VFF (2013)

The use of electrical components for windows and doors is gaining in importance.⁷⁰ The EEE can be combined with more or less all basic type products. EuroWindowor estimates the share of windows and doors with electric function at 1% of the total market share of windows and doors at present. However the market share is expected to increase in the next few years and to reach 3% in the EU, due to a higher focus on intelligent and dynamic houses.⁷¹ The highest share of products with

⁶⁸ EuroWindowor (2014b): Presentation provided for the interview per e-mail on 05.12.2014.

⁶⁹ EuroWindowor (2014a): Interview held on 05.12.2014 with Frank Koos, Ulrike Döbel (EuroWindowor General Secretariat), Britta Hougaard (JELD-WEN, Leader of Task Group 11 “RoHS II” and Member of FEMIB Management Council) and Joachim Oberrauch (Finstral, Chairman EuroWindowor and President EPW).

⁷⁰ Opt. cit. VFF Merkblatt KB.02 (2013)

⁷¹ EuroWindowor (2014c): Input provided to clarification questions, submitted per e-mail on 21.11.2014.

electrical functions are sold in the product group of blinds and shutters,⁷² however, these articles are in most cases not part of the window.⁷³

EuroWindoor has provided some statistic data about windows and doors in general in Europe, but is not able to provide the turnover and structure of companies in the EU at the level of detail relevant for this review (equipment falling in and out of the scope of RoHS).⁷⁴ EuroWindoor estimates the annual market volume with a total of 73.23 million window units (1 window unit = 1.69 m² on average); these statistics are based on 2012 forecasts that include 27 states of the EU (excluding Croatia) and relate to the amount of articles placed on the market.⁷⁵ It should be noted that market share of windows (in terms of numbers sold) is expected to be somewhat higher than that of doors, as most buildings will have more windows than doors.⁷⁶ EuroWindoor stressed that most activity of manufacturers is local (also in light of the size of companies) and thus data for market share of manufacturers of different EU countries is to be similar to the break-down of products placed on the markets of the different EU countries. There is little export and little import of windows and doors according to EuroWindoor.⁷⁷

Statistics from Eurostat for windows and doors have been extensively evaluated by the JRC-IPTS for the purpose of a revision of the Green Public Procurement (GPP) criteria.⁷⁸ The data on production and consumption of windows and doors made of different material (wood, plastic and metal) are presented in Figure 3-2 below.

Figure 3-2: Production and Consumption of Windows and Doors across EU 27 in 2010

| | Units sold (million) | Cumulative value (billion euro) | Highest seller (number units) | Highest seller in value |
|--|----------------------|---------------------------------|-------------------------------|----------------------------|
| Windows, French windows and their frames of wood | 27.3 | 6.8 | Italy UK Poland | Italy Germany France |
| Doors and their frames and thresholds of wood | 92.9 | 6.2 | Spain UK | Germany UK |
| Plastic doors, windows and their frames and thresholds for doors | 60.6 | 11.9 | UK Germany Poland | Germany UK France |
| Iron and steel doors, thresholds for doors, windows and their frames | 56.7 | 6.5 | Poland Germany | Italy Germany France |
| Aluminium doors, thresholds for doors, window, sand their frames | 41 | 11.4 | France Spain Italy | Italy France Germany |

⁷² These products are not the focus of this review, however it should be noted that if they contain electric components and have electric functions, they could also fall in the scope of RoHS and need to comply with the substance restrictions.

⁷³ Opt. cit. EuroWindoor (2014a)

⁷⁴ Opt. cit. EuroWindoor (2014a)

⁷⁵ EuroWindoor (2014b): Presentation provided for the interview per e-mail on 05.12.2014.

⁷⁶ Opt. cit. EuroWindoor (2014a)

⁷⁷ Opt. cit. EuroWindoor (2014a)

⁷⁸ Opt. cit. JRC-IPTS (2012)

Source: JRC-IPTS (2012)

The Eurostat data suggests that wooden products dominate the market at EU27 level. However, stakeholders⁷⁹ indicated that in practice, plastic frames dominate the EU27 market. The official Eurostat statistical data seem to be limited due to inaccurate reporting, estimations and non-reporting e.g. SME business. Germany is a key player within the windows and external doors market, especially in terms of frames made of iron and steel, plastic or aluminium,⁸⁰ which is also confirmed by the information provided by EuroWindoor.⁸¹

Market data on windows and doors with electric function are only very partially available and were already discussed by BIOIS:⁸²

- According to a market study in 2010 for Germany on automated garage and yard gates: 30% of the almost 21 million Germans, who park their car in a garage, use a motorized gate; for yard entrances approximately a quarter of about 10 million gates use an electric drive.⁸³
- Analysis of industrial and commercial doors and shutters in the UK during a five year review period 2002-2006: In volume terms, manual doors accounted for 96% of the total market in 2006. Automatic pedestrian doors represent about 1%. However, it is said to be a fast growing segment of the market in value terms.⁸⁴

EuroWindoor pointed out that windows and doors in general (without or with electric functions) have a high level of customisation. Even if a frame is produced in mass market in different sizes, the assembly of a certain product is almost always related to customer specifications. Electric windows and doors are not a product typically to be found in “do it yourself” markets; most if not all products stocked by these outlets tend to be conventional (i.e. no electric functions). The fact that windows and doors with an electric function are typically customized products means: ⁸⁵

- Electric components can be sold as part of the window, but can also be sold as a separate product and installed together with the window on site. Electric components can also be sold separately for the purpose of retrofitting existing items;

⁷⁹ JRC-IPTS (2012) did not detail in the report which stakeholder provided this data.

⁸⁰ Opt. cit. JRC-IPTS (2012)

⁸¹ Opt. cit. EuroWindoor (2014b)

⁸² Opt. cit. Bio IS (2012)

⁸³ GfK

http://www.edsf.com/fileadmin/user_upload/Dokumente/Newsletter_etc/TTF_2_11_Grabitz_GB.pdf

⁸⁴ MSI (n.y.): Industrial and Commercial Doors and Shutters: UK 2002-2011;
http://www.msi-reports.com/market_research_report_pdfs/CUK3-S.PDF

⁸⁵ Opt. cit. EuroWindoor (2014a)

- It shall usually be cheaper to have the electric components installed as part of the window/door than to retrofit an existing element, because of the simplified manufacturing process; nonetheless the task of fitting these components in windows and doors is often sourced out to other companies, highly skilled in electronics;
- Especially windows, (though also doors) are customized as they vary greatly in their size; this means that estimations of e.g. substances per weight are difficult to make.

Another important aspect is the structure of the manufacturing sector: The window and door industry consists mostly of SMEs (> 97%; see Figure 3-3).

Figure 3-3: Window and External Door Manufacturers in Germany - Size by Employees; Information provided by EuroWindoor

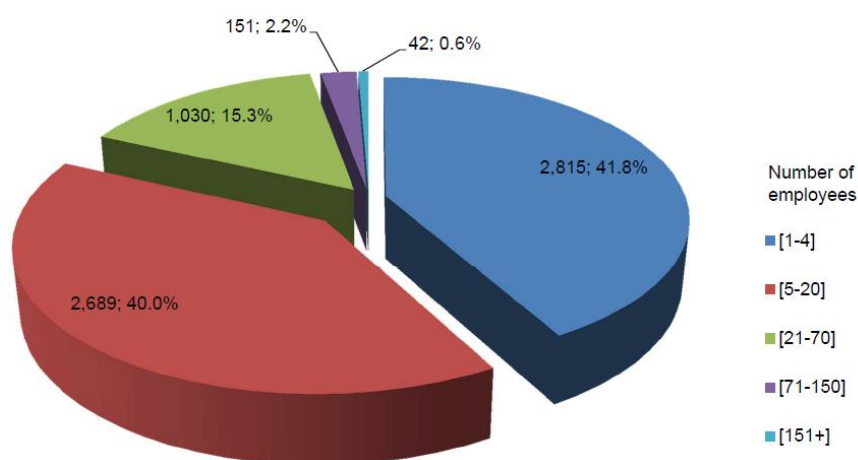

Source: EuroWindoor (2014b)

The fact that most players are SMEs could provide some explanation as to why import and export are of lower relevance, and why most activity of these companies is local. Although windows and doors are only a small part of the market share, their manufacture cannot be linked to specific manufacturers or to a few specific product types in the product range of the manufacturers, as the electric components are easily combined into more or less all product types.⁸⁶

3.4.1 Problem Definition

According to Article 2(1) of the recast, the RoHS 2 Directive applies to “*EEE falling within the categories set out in Annex I*”. On this basis, assuming that windows and doors with electric functions fall under the definition of EEE, they will need to comply with RoHS: Among others, this means that such products will need to comply with the RoHS substance restrictions as stipulated in Article 4(1):

⁸⁶ Opt. cit. JRC-IPTS (2012)

“Member States shall ensure that EEE placed on the market, including cables and spare parts for its repair, its reuse, updating of its functionalities or upgrading of its capacity, does not contain the substances listed in Annex II”

Article 3(1) provides a definition for EEE as *“equipment which is dependent on electric currents or electromagnetic fields in order to work properly and equipment for the generation, transfer and measurement of such currents and fields and designed for use with a voltage rating not exceeding 1 000 volts for alternating current and 1 500 volts for direct current;”*. Article 3(2) specifies that within this definition, *“‘dependent’ means, with regard to EEE, needing electric currents or electromagnetic fields to fulfil at least one intended function”*.

Thus, it is understood that some windows and doors (i.e., with electric functions) fall to some extent within the scope of RoHS, as shall be discussed in the next section. It is further understood that they fall under Category 11 “Other EEE not covered by any of the categories above.”

As a consequence, windows and doors with electric functions are not allowed to contain the substances listed in Annex II of the RoHS Directive, as stipulated in Article 4(1). These substance restrictions apply to all components of windows and doors, which are in scope. Compliance shall need to be fulfilled by 22 July 2019, through substitution of RoHS substances in relevant applications or through the availability of exemptions in Annex III.

Concerns have been raised by stakeholders⁸⁷ that if windows and doors remain in scope, this could result in significant negative impacts. The main concern is that the RoHS compliance of windows and doors with electric functions could result in costs for the conventional windows and doors industry. Stakeholders contend that there is little knowledge at present as to what RoHS substances to expect in what components (window and door components – both electrical and non-electrical components). It is further explained that as the windows and doors sector mainly consists of SMEs and as the supply chain is very complex, individual manufacturers do not have the power to obtain the relevant information from the supply chain for understanding if and where problems with compliance exist.⁸⁸

A further aspect of importance was that there is currently no separate manufacture of non-electric components for products with electric functions and for products without such functions (conventional windows and doors). For example, frames are manufactured on the same production line, regardless of if they are to be used for a product with or without an electrical function. If windows and doors with electric functions are to become compliant, SMEs would have difficulty in changing the manufacture of non-electric components, without this resulting in the compliance of all manufactured articles, in light of the mutual production lines. In this sense,

⁸⁷ Communicated at meeting between EuroWindoor and the EU Commission held in Brussels, Belgium, on 20.05.2014.

⁸⁸ Opt. cit. EuroWindoor (2014a)

concern has been raised that compliance shall result in significant costs for the entire industry and not just related to the manufacture of products with electric functions.⁸⁹

3.4.2 Legislative Background of Windows and Doors

EuroWindoor explained the sector to be highly regulated, e.g. Construction Products Regulation (CPR),⁹⁰ EU Timber Regulation,⁹¹ REACH⁹² as well as the Energy Performance of Building Directive (EPBD) indirectly.⁹³ Specific requirements can also differ on the national level. Furthermore, different European Standards are applicable for windows and doors.⁹⁴

EuroWindoor therefore expects that introducing new materials (substitutes) into the design of windows and doors would be difficult, as each change needs to be compatible with the CPR requirements. Introducing new materials can also be tricky since materials may react with one another over time (products have a long service life and are exposed to changing environmental conditions which can contribute to such effects).⁹⁵

However, the CPR regulation also demands “*information on the content of hazardous substances in the construction product in order to improve the possibilities for sustainable construction and to facilitate the development of environment-friendly products. [...] Information on the content of hazardous substances should initially be limited to substances referred to in Articles 31 and 33 of [REACH]*” (Recital 25). Article 6(5) stipulates that the information on hazardous substances shall be provided together with the declaration of performance (DoP). “The specific need for information on the content of hazardous substances in construction products” was addressed to be analysed and clarified by 25 April 2014 (Article 67(1)). The EU COM commissioned

⁸⁹ Opt. cit. EuroWindoor (2014a)

⁹⁰ European Parliament (2011b), Regulation (EU) No 305/2011 laying down harmonised conditions for the marketing of construction products and repealing Council Directive 89/106/EEC; <http://eur-lex.europa.eu/legal-content/EN/TXT/PDF/?uri=CELEX:32011R0305&from=en>

⁹¹ European Parliament (2010), Regulation (EU) No 995/2010 laying down the obligations of operators who place timber and timber products on the market; <http://eur-lex.europa.eu/legal-content/EN/TXT/PDF/?uri=CELEX:32010R0995&from=EN>

⁹² European Parliament (2006), Regulation (EC) No 1907/2006 concerning the Registration, Evaluation, Authorisation and Restriction of Chemicals (REACH); latest consolidated version available under <http://old.eur-lex.europa.eu/LexUriServ/LexUriServ.do?uri=CONSLEG:2006R1907:20140410:EN:HTML>

⁹³ European Parliament (2002), Directive 2002/91/EC on the energy performance of buildings; <http://eur-lex.europa.eu/legal-content/EN/TXT/PDF/?uri=CELEX:32002L0091&from=EN>

⁹⁴ Standards relevant for the construction sector include: EN 14351-1:2006+A1:2010: Windows and doors - Product standard, performance characteristics – Part 1: Windows and external pedestrian doorsets without resistance to fire and/or smoke leakage characteristics; EN 1155:1997: Building hardware – Electrically powered hold-open devices for swing doors - Requirements and test methods; EN 1158:1997/A1:2002/AC:2006: Building hardware – Door coordinator devices – Requirements and test methods; EN 13241-1:2003+A1:2011: Industrial, commercial and garage doors and gates – Product standard – Part 1: Products without fire resistance or smoke control characteristics.

⁹⁵ Opt. cit. EuroWindoor (2014a)

a “Study on specific needs for information on the content of dangerous substances in construction products”.⁹⁶ The study analysed voluntary certification and labelling schemes in the construction sector that pursue these goals via information of the content of substances in the construction products and conducted a survey among stakeholders. The manufacturers of construction products, especially SMEs, responding to the survey in the study, considered any extension of the current information obligations to be a significant and unjustifiable burden (for the outcome of the study on substances in products, see Section 3.5.1).

In order to elaborate European assessment methods concerning dangerous substances, in 2005 the Commission issued Mandate M/366 to CEN/CENELEC (based on Directive 89/106/EEC), requesting the development of horizontal assessment methods for dangerous substances, as a means to support the companies in the construction sector to comply with the information requirements on hazardous substances.⁹⁷

The EU COM concluded in August 2014⁹⁸ that *“the specific needs for information on the content of hazardous substances in construction products are sufficiently addressed by the current provisions of the CPR, in particular Article 4 in combination with Article 6(5). However, the need for further options to inform final users on the presence of substances in construction products, so as to ensure a high level of protection of the health and safety of workers using construction products and of users of construction works, including with regard to recycling and/or reuse requirements of parts or materials, should be further assessed and, if appropriate, addressed under the relevant instruments available in EU legislation.”*

Against this background, it can be understood, that the sector may be highly regulated, affecting the ease as well as the time needed for introducing new materials and changes to design. However this is also assumed to be true in cases where manufacturers try to introduce innovative functions through design changes. Despite the burden that such changes may create on manufacture, this can be justified by the benefits manufacturers expect from such design changes. Thus, on the same basis,

⁹⁶ RPA and Tecnalía (2013): Study on specific needs for information on the content of dangerous substances in construction products, Final Report prepared for DG Enterprise & Industry 31st October 2013; retrieved from

http://ec.europa.eu/enterprise/sectors/construction/studies/index_en.htm#h2-4

⁹⁷ CEN Technical Committee CEN/TC 351 has undertaken the work requested by Mandate M/366; the work programme can be found at

http://standards.cen.eu/dyn/www/f?p=204:22:0:::FSP_ORG_ID,FSP_LANG_ID:510793,25&cs=135BD767027D4B4E081006EF46B5E957C

The EU COM has created a database on “Legislation on substances in construction products” in order to provide information to manufacturers and standardisers and to mitigate the difficulties arising from the disparity of national provisions during the period where European assessment methods are under elaboration; the database is available at

<http://ec.europa.eu/enterprise/construction/cpd-ds/index.cfm>

⁹⁸ EU COM (2014), Report from the Commission to the European Parliament and the Council as foreseen in Article 67(1) of Regulation (EU) 305/2011 EN, Brussels, 7.8.2014, COM(2014) 511 final; <http://ec.europa.eu/transparency/regdoc/rep/1/2014/EN/1-2014-511-EN-F1-1.pdf>

the consultants infer that where environmental benefits are to be expected from changes to design, this could justify respective costs. Furthermore, in this regard it should be noted that there are additional product sectors in the scope of RoHS, which are highly regulated. Thus the consultants conclude that if this aspect did not justify excluding certain product groups from scope in the past that it would not be in line with the European Union's intentions to make such justifications at present. The fact that the current RoHS substances are addressed by additional legislative regulations and standards would also support that the burden of compliance is lower than in the case of completely new substance restrictions, as certain substances will have already been phased out. Examples for areas where RoHS substances are expected to have been phased out of the production of certain window and door components are provided in Table 3-2.

3.5 Compliance with RoHS

Windows and doors, which will be in the scope of RoHS, will contain both electric and non-electric components. The arguments of stakeholders concerning the burden of compliance have been directed towards the difficulty of documenting compliance in non-electric components, as well as the difficulty of introducing design changes to facilitate such compliance in these components. Furthermore, electric components shall be manufactured by suppliers who also produce components for the EEE sector. The phase-out of RoHS substances in these components is thus expected to have already occurred or to be in line with exemptions already provided in Annex III of RoHS and available for application in electric components. As suppliers should be aware of these aspects, it is also expected that they would be able to supply documentation more easily, in light of being more aware of the presence of RoHS substances in their articles. Thus the focus of this section shall be on the compliance of non-electric components and not on electric components, as a means of identifying possible obstacles for the compliance of these articles.

3.5.1 Burden of Documentation

As already mentioned, the window and door industry consists mostly of SMEs (> 97%). When the SME manufacturers try to obtain information they yield very few results if any. A survey was performed in the supply chain by a European door manufacturer⁹⁹ among 10% of regular suppliers. Although this European door manufacturer is a leading manufacturer of doors in Europe, only about one third of its suppliers responded:

- *“About 10% of regular suppliers were asked.*
- *About 1/3 has responded.*
- *Of the 1/3 who has answered 15-20% has used the option “need investigation” for one or more of the substances asked about (the 6 already regulated + the 4 phthalates expected to be included later).*

⁹⁹ EuroWindow (2014c): Summary of supplier survey regarding RoHS compliance submitted by the European door manufacturer on 08.12.2014.

- *When asked about documentation also 15-20% answered they have no documentation available for one or more of the substances.*
- *About 25% of the respondents had supplier declarations/contractual agreements only. With the knowledge about the complexity of the supply chain and the many steps back to homogenous material level especially this type of documentation leaves a huge task for the manufacturer to evaluate the quality and trustworthiness as required in EN 50581; which again would require at least some technical chemical skills. Those competences are not necessarily available in house and may therefore require some in-source consultancy.*
- *In some of the supplier declaration the term “not intentionally added” is used. It could be questioned if that would make the product more legal in terms of RoHS compliance and the answer is most likely that it wouldn't; in which case an analytical test probably needs to be asked for.”*

This example shows that at present SMEs are limited in their ability to receive information on RoHS compliance from suppliers. Additionally, suppliers are not aware of exact content and not prepared or able to carry out expensive testing in order to provide documentation that a substance is not contained. Also for the possible implementation of RoHS substance substitutes – the industry is too small and the supply chain too complex to persuade suppliers to change manufacture.

However, it should also be noted that until recently, industry was unaware of the RoHS compliance requirement for this sector and thus may have limited experiences in querying and evaluating data from the supply chain.

A supporting development is the fact, that a comparable information requirement to RoHS is stipulated by the CPR Regulation: Information on the content of hazardous substances in construction products (substances referred to in Articles 31 and 33 of REACH) shall be provided together with the declaration of performance (DoP). Thus, information on the REACH candidate list substances is to be collected and transmitted regardless of possible changes in the need to comply with RoHS. In this regard, there exist limitations to compliance with REACH at present as well: E.g. EuroWindow pointed out that components often do not have a DoP, because they are not covered by a harmonized European standard, and therefore information will not be produced in a consistent manner. Besides, safety data sheets for substances used by the supply chain (where these could be provided) have not yet been made available to manufacturers. An independent testing of the components on the presence of RoHS substances is very difficult and expensive according to EuroWindow.¹⁰⁰

Thus it is concluded here, that the windows and doors sector is in developmental/ transition phase with regard to building up a system for gathering and assessing information in hazardous substances in components in general. Further time may allow receiving more information to enable documentation, as the supply chain is

¹⁰⁰ Opt. cit. EuroWindow (2014b)

complex and it shall take time for the need for documentation to travel through the supply chain and back to manufacturers. It should further be noted that additional product groups are in the scope of RoHS which could have similar difficulties – as products which are not EEE in themselves, but that have secondary electric functions in some cases. Nonetheless, at present it has not been found justified to exclude such products, aside from Pipe Organs.¹⁰¹

3.5.2 Potential of Components for Containing RoHS Substances

For non-electric components a first step is to understand the possible applications of RoHS substances, as well as possible substitutions that could be applied in window and door components. EuroWindow claimed that many components and materials are used to manufacture window and door components: For example, the frame is usually constructed of a number of materials: the plastic parts of the frame, material for insulation of the windows, gaskets, spacers, etc. EuroWindow provided some information on window and door components that potentially could contain RoHS substances in Table 3-1.¹⁰²

Table 3-1: Window and Door Components Potentially Containing RoHS Substances

| RoHS Substance | Component of W&D potentially containing RoHS substance as indicated by EuroWindow* | Additional information from the RPA study** |
|---|--|---|
| Lead (0.1 %) | In recycled PVC and metal compounds (hardware) | Might be present as contaminant in recycled wood and in pigments and additives. |
| Mercury (0.1%) | - | |
| Cadmium (0.01 %) | In recycled PVC and metal compounds (hardware) | |
| Hexavalent chromium (0.1 %) | - | |
| Polybrominated biphenyls (PBB) (0.1 %) | In plastic, flame retardant | |
| Polybrominated diphenyl ethers (PBDE) (0.1 %) | Flame retardant in rubber | |
| Substances likely to be added to RoHS Annex II | | |
| Hexabromocyclododecane (HBCDD) | Flame retardant for plastic | |
| Bis (2-ethylhexyl) phthalate (DEHP) | Softener in rubber (PVC) | Sealants, adhesives, in surface treatments or coatings of wood products. |
| Butyl benzyl phthalate (BBP) | Softener in rubber, In glue | |
| Dibutylphthalate (DBP) | Softener in rubber and plastic Hardener for plastic Wood preservatives | |

Sources: *: EuroWindow (2014a); **: RPA and Tecnalía (2013)

¹⁰¹ Opt. cit. BIOIS (2012)

¹⁰² Opt. cit. EuroWindow (2014a)

The RPA study (2013)¹⁰³ analysing voluntary certification and labelling schemes in the construction sector found that despite the diverse nature of the schemes, some substances and substance groups appear to be a common target for many schemes. These include substances classified as carcinogenic, mutagenic, reprotoxic, persistent organic pollutants, heavy metals and phthalates. Thus RoHS substances are already addressed by voluntary certification and labelling schemes in the construction sector: Among the schemes certifying window and/or door products e.g. BASTA- Guidance to Sustainable Construction Materials (Sweden) prohibits lead, mercury and cadmium and generally substances with certain hazardous properties¹⁰⁴ and German Society for Sustainable Building Navigator (DGNB Navigator) bans lead and chromium and its compounds.

Besides the experiences gained through certification and labelling schemes, the RoHS substances are also covered by other EU regulations and international agreements. An overview on the EU legislation and international agreements concerning the RoHS substances is presented in Table 3-2.

Table 3-2 shows that basically most RoHS substances are tackled by different EU legislation or international agreements such as the Stockholm Convention on Persistent Organic Pollutants (POPs).¹⁰⁵ It can be concluded that although the supply chain for windows and doors at present does not sufficiently cooperate in providing information, this problem might be solved as the supply chain is impacted by compliance of other product groups, e.g. by the ELV-Directive¹⁰⁶ when components are also manufactured for the automotive industry. This will lead to an in-direct phase-out in light of RoHS and additional legal requirements.

This might ease the burden of documentation. However it seems that the windows and doors sector needs to establish knowledge on the presence of hazardous substances in their components and in the best case a sectoral approach for sustainable chemical management and for research of alternative substances.

¹⁰³ Opt. cit. RPA and Tecnalía (2013)

¹⁰⁴ Substances with the following hazardous properties: Carcinogenic, mutagenic, toxic to reproduction, effects during lactation, endocrine disrupting, persistent, bio accumulative and toxic organic compound, very persistent and very bio accumulative organic compound, dangerous to ozone layer, sensitising, acute toxicity, acute toxic with danger of serious irreversible damage to health, high chronic toxicity, volatile organic compounds, dangerous for the environment; see JRC-IPTS (2012), Table A2-7

¹⁰⁵ Parties that ratified the Stockholm Convention are required to prohibit and/or eliminate the production and use, as well as the import and export, of the intentionally produced POPs that are listed in Annex A to the Convention or to restrict the production and use, as well as the import and export, of the intentionally produced POPs that are listed in Annex B to the Convention.

¹⁰⁶ European Parliament (2000), Directive 2000/53/EC on end-of life vehicles;
<http://eur-lex.europa.eu/legal-content/EN/TXT/PDF/?uri=CELEX:02000L0053-20130611&qid=1405610569066&from=EN>

Table 3-2: RoHS substances and their corresponding provisions in other EU regulations and international agreements

| RoHS Substance | Tackled by Other Legal Frameworks | Comment |
|--|---|--|
| Lead (0.1 %) | <p>Banned by ELV-Directive for use in material and components for vehicles;</p> <p>REACH Annex XVII C entries 16 and 17 restricts the use of lead carbonates and lead sulphates in paints, restriction of lead and its compounds in entry 63 not specific for construction sector;</p> <p>Three lead compounds on REACH Annex XIV (List of authorised substances);¹⁰⁷</p> <p>Includes a number of lead compounds on the REACH Candidate list</p> | <p>Substances on REACH Annex XIV (Authorisation list) cannot be manufactured or used in EU manufacture;</p> <p>For substances on the REACH Candidate list, information requirements according to REACH Article 31 and 33 apply, thus also under CPR with the DoP;</p> <p>Where components are mainly produced for the automotive industry, e.g. gaskets; components without lead, mercury, cadmium and hexavalent chromium will be available an ELV exemption will exist; if not yet phased out (e.g. screws with Cr VI),¹⁰⁸ it compliance in such cases would be easier and more a matter of time (assuming not yet to have happened as window and door manufactures may not have sufficient market share to justify manufacture with substances for these products if substitutes applied in other sectors.</p> |
| Mercury (0.1 %) | <p>Banned by ELV-Directive for use in material and components for vehicles;</p> <p>REACH Annex XVII, entry 18 and 18a restrict among others the use of mercury compounds in the preservation of woods</p> | |
| Cadmium (0.01 %) | <p>Banned by ELV-Directive for use in material and components for vehicles;</p> <p>REACH Annex XVII, entry 23 restricts among others the use in synthetic organic polymers and in paints;</p> <p>Four cadmium compounds on the REACH Candidate list.</p> | |
| Hexavalent chromium (0.1 %) | <p>Banned by ELV-Directive for use in material and components for vehicles;</p> <p>REACH Annex XVII, entry 47 restricts use in Cement and cement-containing mixtures;</p> <p>Chromium compounds on the REACH Candidate list.</p> | |
| Polybrominated biphenyls (PBB) (0.1 %) | <p>REACH Annex XVII, entry 8; restricts use in textile articles.</p> | |

¹⁰⁷ The following lead compounds are on REACH Annex XIV: Lead chromate, Lead sulfochromate yellow, Lead chromate molybdate sulphate red

¹⁰⁸ The example of screws with Cr VI was experienced by the electric bicycles industry when assessing RoHS compliance; see Oeko-Institut (2014), Gensch, C.-O.; Baron, Y.; Diesner, M.-O. Additional Input to the Commission Impact Assessment for a Review of the Scope Provisions of the RoHS Directive Pursuant to Article 24(1), Report for the European Commission DG Environment under Framework Contract No ENV.C.2/FRA/2011/0020, Final Report; http://rohs.exemptions.oeko.info/fileadmin/user_upload/reports/201406012_RoHS_Scope_Review_report_final.pdf

| | | | |
|--|--|---|--|
| <p>Polybrominated diphenyl ethers (PBDE) (0.1 %)</p> | <p>EU POP regulation 850/2004 bans the use of hexa-, hepta-, tetra- and pentabromodiphenyl ether as substances, preparations, articles or as constituents of the flame-retarded parts of articles.</p> <p>On Stockholm Convention Annex A (eliminate production and use of substances) of the (hexa-, hepta-, tetra- and pentabromodiphenyl ether)</p> | <p>No manufacture and use of hexa-, hepta-, tetra- and pentabromodiphenyl are permitted in the EU; Globally prohibition of the PBDEs depends on ratification of the Stockholm Convention.</p> | |
| <p>Substances likely to be added to RoHS Annex II</p> | | | |
| <p>Hexabromocyclododecane (HBCDD)</p> | <p>On REACH Annex XIV Added to Annex A of the Stockholm convention by 26th November 2014 REACH Candidate list</p> | <p>Substances on REACH Annex XIV (Authorisation list) cannot be manufactured or used in EU manufacture after sunset date;</p> <p>As HBCDD is on the Candidate list, information has to be provided attached to the DoP according to the CPR.</p> <p>Globally prohibition of the HBCDD depends on ratification of the Stockholm Convention;</p> <p>For substances on the REACH Candidate list, information requirements according to REACH Article 31 and 33 applies, thus under CPR with the DoP.</p> | |
| <p>Bis (2-ethylhexyl) phthalate (DEHP)</p> | <p>On REACH Annex XIV REACH Candidate list</p> | <p>Substances on REACH Annex XIV (Authorisation list) cannot be manufactured or used in EU manufacture (for these phthalates the phase out is by 2015)</p> | |
| <p>Butyl benzyl phthalate (BBP)</p> | | | <p>Additionally, RoHS extends restriction to imported articles; this would prevent unfair competition between EU and non EU manufacturers / suppliers;</p> |
| <p>Dibutyl-phthalate (DBP)</p> | | | <p>For substances on the REACH Candidate list, information requirements according to REACH Article 31 and 33 applies, thus under CPR with the DoP.</p> |

E.g. for hexavalent chromium (Cr VI) in galvanised metals for corrosive protection, it seems that the world is slowly phasing out of Cr VI galvanisation. It could be that this is already no longer used in window and door applications and it could be that this will phase-out with time, regardless of whether the products are excluded from the Scope of RoHS or not. E.g. a stakeholder¹⁰⁹ from the medical industry stated during an exemption request evaluation that Cr VI passivation coating processes are expected to be phased out by the medical sector in new products by 2014, but may still be in circulation in refurbished parts. This is an example how other industry sectors manage the same problem.

As understood from industry, recycled PVC could contain a lead content greater than 0.1% due to the former use of lead in PVC as stabilizer. The content of lead used in window profiles was estimated at 2% in 2004; however, the European Stabilisers Producers Association (ESPA) and the European Plastics Converters (EuPC) committed to the replacement of lead stabilisers and to phase out lead in window profiles in 2015.¹¹⁰

Similar exemptions in the ELV Directive specify higher thresholds for lead in light of possible unintentional use, such as Exemption 2(c) and Exemption 3 for various alloys. As RoHS has the same exemptions (Exemption 6(b) and 6(c) – reference to unintentional use not made in Directive) this suggests that non-intentional use could justify an exemption if the use of the substance creates environmental benefits greater than the environmental costs thereof. The use of plastic frames dominates the EU27 according to stakeholders.¹¹¹

3.6 Critical Review

3.6.1 Difficulty of Compliance

It can be concluded that where windows and doors shall fall in scope, manufacturers may face some difficulties of compliance as explained above. It is understood that at least some windows and doors with electric functions will fall in scope. A categorisation of windows and doors has been drawn up in Table 3-3 to facilitate a better understanding as to what part of windows and doors placed on the EU market are in the scope of RoHS and would need to comply.

¹⁰⁹ COCIR (2011), Application for new exemption, Submitted 29.9.2011, available under: http://rohs.exemptions.oeko.info/fileadmin/user_upload/RoHS_VI/Request_2/COCIR_-_Exemption_request2_-_X_ray_and_other_parts_reuse.pdf

¹¹⁰ PE Europe et al. (2004), PE Europe GmbH, Institut für Kunststoffkunde und Kunststoffprüfung (IKP), Institut for Produktudvikling (IPU), DTU, RANDA GROUP (2004): Life Cycle Assessment of PVC and of principal competing materials Commissioned by the European Commission, July 2004; http://ec.europa.eu/enterprise/sectors/chemicals/files/sustdev/pvc-final_report_lca_en.pdf

¹¹¹ Opt. cit. JRC-IPTS (2012)

Table 3-3: Categorization of Windows and Doors (W&D) with regards to the scope of RoHS

| Categorisation of Windows and Doors (W&D) | Scope of RoHS |
|--|---|
| W&D without electric functions – do not fall under the definition of EEE. | Out of scope |
| W&D where the electric function is a later installation (retrofit) – the electric component is sold separately and at a later time and shall need to be RoHS compliant. However, as the window or door, in which it is to be installed are to be placed on the market as an article with no electric functions, they would not need to be RoHS compliant and would not need to comply with RoHS retroactively. | Out of scope |
| W&D where window/door and electric component are already integrated as a single product at time of delivery to the client. Regardless of the mention of separate items on the invoice, all items are integrated and packaged together by the manufacturer, and delivered to the client as a single product to be installed on-site. | Assumed to be in scope |
| W&D where window/door and electric component are installed at the same time, but sold separately by different manufacturers. Both will be delivered to the client in separate packages and integrated into a single product on site – assumed to be less common in new installations. | Unclear – assumed to be empty group and possibly out of scope |
| W&D where electric function is not an integral part – unclear on what basis a component is defined as not integral – see explanations below. | Out of scope |
| W&D where electric function is an integral part - unclear on what basis a component is defined as integral – see explanations below. | In scope |
| Large scale fixed installations – in light of the criteria for defining an article as LSFI it is assumed that windows and doors shall only fall under this exclusion in rare cases. | Out of scope |

It is clear from the RoHS Directive that windows and doors without electric functions are not in scope (not EEE), thus it is understood that they will not need to comply with the substance restrictions. Nor shall such articles need to comply at a later period if they are retrofitted with electric components, as the article first placed on the market, and in this case first installed was not an EEE and the Directive and its requirements thus would not apply. Only the electric components to be retrofitted will need to comply, as they are considered a product which falls under the definition of EEE at the time placed on the market.

However when a window or a door are to be installed as an article with an electric function, it is not straightforward to determine in what cases compliance with the RoHS substance restrictions is required. In the consultant’s opinion, it seems that this could depend in part on the aspects of sales of the various products and or components, such as:

- The company or companies who provide the article/articles to be installed in a building;
- The warranty or warranties of articles to be installed in a building.

Though it is clear that some components of a window or door will be manufactured by suppliers and others by the original equipment manufacturer (OEM), the OEM is the manufacturer who sells the product to the end-user. The OEM may assemble all components or in some cases sub-assemblies and components from some suppliers. Regardless of how much of an article is manufactured by the OEM, it will have the obligation to the client of fulfilling the warranty conditions in the case that a certain component fails or requires repair. This is assuming that the window / door is supplied as a single element to be installed within a building.

In certain cases however, the windows or doors shall be supplied by one OEM and the electric components by a second OEM. This is normally the case when the openings of a building are retrofitted with electrical components, however, in theory, this could also be possible at the time the opening is installed for the first time. As it is understood from EuroWindoor¹¹² that it shall usually be cheaper to have the electric components installed as part of the window/door than to retrofit an existing element, this is assumed to be less common for new installations.¹¹³ In any case, such cases are understood to be distinguished from the single OEM case, by the fact that each OEM shall have a separate warranty for the product it has supplied.

A further aspect of importance here is understood to be mentioned in the RoHS 2 FAQ Document¹¹⁴ regarding the electric component being integral in the product. Q.7.1 explains *“All equipment that has at least one intended function which is dependent on electric current or electromagnetic fields, or that generates or transfers or measures such currents and fields is EEE. Even if the electric function is only a minor element of the equipment, the definition still applies. [...] In all these cases the electric function is an intended and integral part of the product’s functionality, and the full functionality of the equipment is at least impaired (i.e. it does not work properly) if that electrical function fails. [...] For the example of a wardrobe with lights, even if sold as a single unit, a distinction between the piece of furniture and the electric/electronic device the piece is or can be equipped with has to be drawn. If the lighting is EEE in itself and both the lighting and the wardrobe can be separated and used as fully functional separate products, only the electric/electronic equipment (the lighting) is in the RoHS 2 scope. The furniture itself would then be outside the scope.”*

In the case of windows and doors with electric functions, in the consultants’ opinion, it is questionable if both the window/door and the electric components will be fully functional items if they are separated after they have been integrated into a single product. One could argue that the window or door would still be completely operative

¹¹² Opt. cit. EuroWindoor (2014a)

¹¹³ On this basis, as the same OEM who manufactured an opening, could later retrofit it, one could argue that the OEM could also manufacture and sell the opening and the electronic components separately, to be assembled on site as a single unit, however as it is said to be cheaper to have the electric components installed as part of the opening, this is expected to be a theoretical case.

¹¹⁴ EU COM (2012), European Commission, RoHS 2 Frequently Asked Questions (FAQ) Document, available under http://ec.europa.eu/environment/waste/rohs_eee/pdf/faq.pdf, last accessed 18.12.2014

as a manual application if the electric component is to be removed. However in this regard, it is also to be understood that the application shall be significantly different from that intended in its design. Though EuroWindow have explained that in some cases electric components are removed and the article is left as a manual one, in most cases, the client will have purchased the article with the intention that it shall have a certain electric function (automated opening, sensor function connected with a central controlling system etc.). Once this function is removed, the article is impaired, in the sense that such intended functions cannot be fulfilled and that it is no longer equivalent to the initial product in terms of electric functionality. The fact that the window can still function manually is beside the point. This is further supported by the understanding that windows and doors with electric functions will have a higher price than conventional items. Furthermore, in the case of a separation, it is further understood that the electric component shall become devoid of function, further supporting the notion of integrality. It is possible that certain fixtures may exist in which the notion of integrality will be different, however at present the consultants are not aware of such cases.

A large scale fixed installation is defined by Article 3(4) of RoHS as “*a large-scale combination of several types of apparatus and, where applicable, other devices, which are assembled and installed by professionals, intended to be used permanently in a pre-defined and dedicated location, and de-installed by professionals*”. However the legal text does not explain what ‘large-scale’ means. The RoHS 2 FAQ document provides an indicative list on how to interpret the term ‘large-scale’, though this document is not legally binding.¹¹⁵ Though some of the LSFI definition aspects also apply to windows and doors, in the consultants’ opinion, most windows and doors would not be seen as large-scale, if the RoHS 2 FAQ criteria are to be followed. Though some windows or doors may have exceptionally large scale, only an individual assessment of such articles against the RoHS 2 FAQ criteria could allow concluding if they would benefit from the LSFI exclusion. The RoHS 2 FAQ clearly states that the burden of proof is with the responsible economic operator. Where a tool or installation does benefit from the exclusion, all constituent components that are part of it when placed on the market are also excluded from RoHS, and thus do not need to comply with the substance restrictions.

¹¹⁵ Op. cit. EU COM (2012), Q3.1 provides an indicative list of criteria for defining large scale:

- If, when installing or de-installing the installation, it is too large to be moved in an ISO 20 foot container because the total sum of its parts as transported is larger than 5,71m x 2,35m x 2,39m, it can be considered large-scale.
- The maximum weight of many road trucks is 44 tonnes. Thus if, when installing or de-installing the installation, it is too heavy to be moved by a 44 tonne road truck, because the total sum of its parts as transported weighs more than the truck's load capacity, it can be considered large-scale.
- If heavy-duty cranes are needed for installation or de-installation, the installation can be considered large-scale.
- An installation that does not fit within a normal industrial environment, without the environment needing structural modification, can be considered large-scale. Examples for modifications are modified access areas, strengthened foundations etc.
- If an installation has a rated power greater than 375 kW, it can be considered large-scale.

EuroWindoor have questioned whether windows and doors could be excluded on the basis of Article 2(4)(c), as they are installed into buildings which are not in the scope of RoHS. The RoHS 2 FAQ explains that “Article 2(4)(c) refers to “another type of equipment” which is outside the scope of the directive. Buildings are not considered equipment for the purposes of RoHS 2. Therefore equipment that is installed in a building cannot be excluded on the basis of Article 2(4)(c)”.¹¹⁶

3.6.2 Policy Options

The policy options analysed are the following:

Option 1 (Baseline scenario): As per the current RoHS 2 legal text, the compliance of windows and doors with electric functions shall be established through the phase out of the RoHS restricted substances or through the use of valid exemptions listed in Annex III (at present or in the future) and available for the respective applications. Windows and doors with electric functions shall be considered to be in scope of RoHS (required to comply with the substance restriction) as discussed above. This option is understood to be the baseline of comparison.

Option 2 (Exclusion scenario): Windows and doors with electric functions are to be excluded from the scope of RoHS through adjustment of Article 2(4).

3.6.3 Impact Indicators

To clarify if an exclusion from the scope of RoHS would be justified, the analysis of the two options, must demonstrate that the benefits expected from the implementation of each scenario would be similar or larger than possible costs therefor. The overarching objective of the Directive is to contribute “*to the protection of human health and the environment...*”. This would require that costs and benefits relevant for the environment, for the economy and for society would be reviewed. On this basis, the following impact indicators have been chosen as relevant in this context:

¹¹⁶ Op. cit. EU COM (2012), Q4.3

Table 3-4: Impact Indicators for the Product Group Windows and Doors (W&D) with Electric Function

| Environmental indicators | Economic indicators | Social indicators |
|---|--|-----------------------|
| Use of RoHS substances in the manufacture of W&D with electric functions | Possible changes to market structure (including wider impact on trade with non-EU countries) – mainly relevant where components are imported | Impacts on employment |
| Emissions of RoHS substances during the life cycle, with a focus on the waste phase | Impacts to manufacturing costs | Impacts on consumers |
| Energy use | Impacts across the supply chain (suppliers and manufacturers of components, repair enterprises) | Impacts on health |
| | Possible impacts on consumers (product quality and availability) | |

3.6.4 Environmental Impacts

The windows and doors industry is still understood to be in the process of obtaining information on the presence of RoHS substances in products at present (December 2014). Based on EuroWindow input (explained in Section 3.5.1) results of this effort are still forthcoming and the process of collecting information and documentation may require further time. This has further been explained to be why the windows and doors sector is still not in a position to provide a precise picture of the presence of RoHS substances in windows and doors with electric functions, and particularly those present in non-electronic components. It is assumed that basically compliance is underway, at least in part, regardless of efforts of the industry but rather in light of other legislative requirements on hazardous substances and restrictions of the same substances relevant for manufacturers from other sectors who work with suppliers of the same components.

It should further be noted that despite statements that RoHS could have impacts on the market share of windows and doors with electric functions, that such an impact is assumed to be small and possibly even negligible, as manufacturers shall always be able to separate between windows and doors and electric components in terms of manufacture, sale and installation. Even if this shall mean that customers shall need to pay more, retrofitting windows and doors already installed in buildings shall continue to be possible and shall allow avoiding the need for non-electric components to comply with RoHS.

The following summarises the relevant environmental impact indicators:

- **Use of RoHS substances in the manufacture of W&D with electric functions:** To begin with, it is assumed that electric components used in windows and doors shall either already be compliant with the RoHS substance restrictions, or shall

be before 22 July 2019. As explored above, there exists uncertainty as to the presence of RoHS substances in other than the electric components of windows and doors. As the RoHS substances are also tackled by other EU legislation (or phased out through restrictions relevant to other products using similar components) it is assumed that phase-out of these substances shall occur in the long-term regardless of the RoHS Directive. However, this process may occur more quickly if the RoHS Directive is still to apply, as the 2019 deadline shall motivate industry to make an effort, either towards substitution or towards receiving exemptions to provide more time for transition. As phase-out is expected to have already occurred in part, environmental impacts are expected to be small; however, distribution over time may change. In this regard, some differences may also be relevant where components are imported, as some legislation (such as REACH Annex XIV) will not restrict the use of substances in articles manufactured in non-EU countries. Here the use of some RoHS substances may still be more common, where components are only used in products where similar restrictions do not exist. As such components would probably be imported by most EU manufacturers, this is assumed not to affect the total amounts used, but rather the distribution of possible emissions between EU and non EU countries. In this regard, Option 1 is estimated to have a small positive environmental impact.

One could argue that compliance of windows and doors with electric functions with the RoHS Directive shall impact the use of RoHS substances in non-electric components and thus also in conventional windows and doors in light of the mutual production lines. However, as already mentioned, it is understood that compliance will already be underway in light of changes to component manufacture brought about by other users of components with similar restrictions. Furthermore, if such costs would be significant, the windows and doors sector could always opt to retrofitting electric components, in order to avoid compliance of these components and respective costs.

- **Emissions of RoHS substances during the life cycle, with a focus on the waste phase:** The electrical component is expected to have a shorter life time than the window and door components and will need to be replaced at least once within the service life of these products. However, generally windows and doors are installed and uninstalled by professionals. The electrical component will be treated according to WEEE¹¹⁷ requirements in both options. As for the non-electric parts, recycling schemes for construction products e.g. plastic frames; exist according to stakeholders.¹¹⁸ As product service life and the amounts of substances used in various components are not expected to change in light of the RoHS Directive, impacts would be expected to be similar in both options. Should the base-line scenario create a change to product

¹¹⁷ European Parliament (2012) Directive 2012/19/EU on waste electrical and electronic equipment (WEEE) (recast); <http://eur-lex.europa.eu/legal-content/EN/TXT/PDF/?uri=CELEX:32012L0019&from=EN>

¹¹⁸ Opt. cit. EuroWindor (2014a)

portfolios in terms of decreasing the market share of windows and doors with electric functions, this would lead to a parallel reduction in the amount of emissions expected, as less electric components would be used for such products. That said, manufacturers could phase-out of manufacturing products, in which the electric function is integrated, requiring such components to be installed as a retrofit. In this way they would avoid having to deal with the compliance of windows and doors, which would only be required from the components to be retrofitted. Thus, such differences are expected to be negligible.

- **Energy consumption:** The trend for energy efficiency e.g. thermal performance is mentioned to be relevant in the manufacture and design of windows, with classical solutions focused on design optimization through the use of double and triple glazing.¹¹⁹ However, EuroWindow has also mentioned that in some cases electric functions can assist in conserving energy, e.g. when sensors and automated functions allow for regulating the closing and opening of an opening in consequence to weather conditions. This may save energy consumption otherwise needed for heating or cooling of internal spaces. For external doors, there is a lack of environmental studies. One could assume that an impact could arise from the fact that automatic windows and doors provide less loss of heat (or cooling capacity) and thus less energy is needed for acclimatisation. However the extent of energy savings is related to design; e.g. revolving doors may efficiently minimize heating and air conditioning losses (as the air trapped within works as a buffer), but this shall be true for all models available on the market, both manual or electric versions. In other openings that open or close automatically, loss of heat (or cooling capacity) shall depend on how quick the opening is operated, and this shall not necessarily be different from manual doors. Thus, as data is not available to quantify such benefits, it is difficult to quantify if they shall be significant or not. In any case. As stated above, it is not expected that the need to comply with RoHS shall have a large impact on the market share of windows and doors with electric functions. Thus any impacts are considered to be negligible as use of such functions in opening is not expected to change.

The consultants conclude that environmental impacts expected to derive from the compliance of the sector with RoHS have already begun. If windows and doors are to be excluded from the Directive, a significant change in this trend is not expected.

To conclude, in terms of environmental impacts, the only area where differences are expected between the two options are tied with the amount of RoHS substances and the distribution of their use in articles where phase out is expected over time.

3.6.5 Economic Impacts

Though windows and doors are only a small part of the market share, their manufacture cannot be linked to specific manufacturers or to a few specific product

¹¹⁹ Opt. cit. JRC-IPTS (2012)

types in the product range, as the electric components are easily combined into more or less any product type/model.¹²⁰ On the basis of this statement it is expected that the burden of RoHS compliance will be distributed more or less evenly. This even distribution however, is not to say that costs can be disregarded, but just that all manufacturers shall be affected similarly. Though a few companies are larger and could possibly deal with such changes more easily in light of size, most manufacturers are SMEs and thus regardless of actual costs, will be more sensitive to dealing with such changes.

Stakeholders have not provided data concerning the actual costs of compliance, but they claimed such costs to be a significant and unjustifiable burden; the same industry raised similar claims concerning the information requirements on hazardous substances of the CPR regulation.¹²¹ Thus, costs and administrative burdens are understood to arise in any case; RoHS compliance could benefit from the compliance with documentation requirements of the CPR, as this would mean that documentation is available and that such costs are at least related to some degree to compliance with other legislation.

If the costs of compliance with the substance restrictions are to be severe, this could bring about a change of product portfolio diversity of manufacturers in some cases. This could mean that the market share of windows with electric functions changes as manufacturers decide that the related costs would not justify continuing to provide such products. However as manufacturers in such a case could shift away from integrated products to retrofitted products, such costs could be avoided through avoiding the need to comply with legal requirements of RoHS (windows and doors which are retrofitted do not need to comply). As retrofitting is already common, it is assumed that the additional costs both for manufacturers and for customers would be acceptable. In such a case, costs related to compliance with RoHS would only be relevant for the manufacturers of electric components, however as other manufacturers of EEE have had such costs, this is understood to be justified in any case.

Furthermore, it is understood that the RoHS substances shall be phased out of many components regardless of windows and doors with electric functions needing to comply. This process is assumed partly underway and thus costs shall be a thing of the past in some cases. This means that the range of expected costs is expected to be small. Furthermore, costs of design changes required to comply are assumed not to be directly related to RoHS – such changes shall occur in many cases in components manufactured by suppliers and could thus affect OEMs in terms of costs of purchasing components. However the windows and doors sector was explained to have limited power to influence such design changes, which are thus understood to be a result of the needs of other product manufacturers, and thus such costs could not be avoided, regardless of RoHS. It is assumed that in areas where this could be different (manufacture influenced predominantly by the needs of windows and doors),

¹²⁰ Opt. cit. JRC-IPTS (2012)

¹²¹ Opt. cit. RPA and Tecnalia (2012)

such as unintentional use of lead in plastic frames, that exemptions could be applied for to allow a slower transition period.¹²²

It is possible that manufacturers would increase costs of products to cover their own additional costs (possibly for both conventional and non-conventional items, in light of the small market of the latter in terms of its ability to carry costs of compliance). As changes in the use of RoHS are understood to be underway in any case, such increases shall not be tied directly to the compliance with RoHS.

Furthermore, if manufacturers are to shift from manufacturing integrated items to retrofitted items, consumers may have impacts in terms of a possible change to product diversity (a shift to retrofitted products would be understood as a change in available product range for consumers).

RoHS 2 compliance should affect all window and door manufacturers in the EU equally, which means that no competitive pressures within the European Union should be expected. Most manufacturers (OEMs) are understood to operate on a local basis, thus such impacts are not expected outside the EU. In contrast, some components may be sourced from non-EU countries and thus in cases where suppliers do not provide components for products subjected to similar substance restrictions, compliance may result in design changes and costs for suppliers that would be passed on to clients (manufacturers of windows and doors) and finally also to consumers. In light of the available information, such components are understood to be less common and thus such costs are expected to be small in range.

The various economic impact indicators have been analysed against this background:

- **Impacts to market structure:** As the windows and doors market is mainly local, in case of inclusion in the scope of RoHS, there are no expected changes on the market share of EU and non-EU manufacturers. The financial burden will be equally distributed among regional SMEs, though in light of their size, companies may have difficulties coping with impacts if the transitional period is not sufficient.
- **Impacts on manufacturing costs:** The costs of compliance are claimed to be significant by stakeholders. However detailed information was not provided in this regard and thus a range of costs could not be estimated. Though manufacturers could change as RoHS substances are phased out, this is not understood to be a direct result of compliance of windows and doors with RoHS, but more of compliance of other products (using similar components) with RoHS and with other legislation. Thus regardless of the significance of costs, only a small difference if any, is expected to be related directly to RoHS. As documentation of compliance with substance restrictions is also required through other legislation, here too the related burden for manufacturers related directly with RoHS is expected to be small or even negligible. It should

¹²² As Pb is no longer used in manufacture, its content in recycled plastics is expected to decline with time, thus it is assumed that the exemption would be renewed until it can be determined that Pb quantities in recycle are below the RoHS substance threshold.

also be noted that such costs are also carried by manufacturers of all EEE and that it is understood that some compliance costs are acceptable; otherwise such legislation requirements would not be approved by regulators to begin with.

- **Impacts across the supply chain:** The supply chain is assumed to be resilient, as it has been communicated that suppliers do not depend on the window and door sector as a single source of income. This is further supported by the statements that the window and door sector does not have sufficient market share to influence suppliers in terms of complying with substance restrictions or documentation requirements. To conclude, should any impacts occur, they would be associated with Option 1; these, however, are assumed negligible. It is understood that there are no enterprises dependant on the production of windows and doors with electric functions; as the market share of conventional windows and doors is above 95% of the total market share. Thus manufacturers shall continue to manufacture conventional products in any case and to purchase components for such products from suppliers, which shall still be the core business between these players. The possible shift to retrofitted products could also have a positive effect on some suppliers, as the installation of windows and doors and of electric components shall be carried out separately and thus require both the manufacturer of the window or door and the manufacturer of the electric components to have professional personnel that install such products in buildings.
- **Possible Impacts on Consumers:** It can be expected that the burden of compliance will have impacts on the price of windows and doors with electric function for consumers. Such a change shall occur regardless of RoHS where substances are phased out any way, but shall still probably result in higher product costs where compliance with substance restrictions is only RoHS related (assumed to be a small range of costs). Furthermore, a possible shift towards retrofitted products shall also result in higher costs for consumers, though these are understood to be acceptable as retrofitting occurs for some consumers at present. It is thus concluded that the need for windows and doors to become RoHS compliant would have a direct impact on the consumer's choice (range of integrated products) and on prices of products (retrofitted but also in some cases integrated products), though in lack of other evidence it is assumed that the impact related to RoHS shall be small.

To conclude, economic impacts may occur in some areas, as a result of the inclusion of windows and doors with electric function in the scope of RoHS.

3.6.6 Social Impacts

Concerning social impacts, it is assumed that both impacts on employment and impacts on consumers would be sensitive to changes in the number of windows and doors to come onto the market, as well as to the difference in the share of windows and doors retrofitted with electric functions in comparison to integrated windows and doors with electric functions.

- **Impacts on employment:** A significant shift of manufacture between EU and non-EU countries is not expected; manufacture is local in principle with most

manufacturers being SMEs and acting on a regional scale. Additionally it is understood that there is little specialisation of certain firms in certain models, but rather that all manufacturers produce both, conventional windows and doors as well as ones with electric functions. Thus it is also assumed that any efforts needed to comply will be required by all manufacturers and thus affect all similarly. Though there may be some impacts on suppliers, these are not expected to lead to a significant increase or decrease in manufacture, and would thus not impact employment. , To summarize, employment is not expected to be affected in either option.

- **Impacts on consumers:** The burden of costs is likely to result in a higher price of the windows and doors with electric function. In terms of compliance with the RoHS substance restrictions, it is assumed that many cases of phase-out of substances shall occur anyway or have already occurred in the past. Nonetheless, costs for manufacturers are still likely to be higher in light of areas where this sector is the predominant client of certain suppliers or in light of the costs of documenting compliance over time. This may have a certain effect on the prices of items for consumers as these costs shall probably be passed on. Furthermore any shift between integrated products to retrofitted products shall also impact consumers in terms of the available product range, with retrofitted products also being a bit more expensive. Despite these changes in costs, consumers are not expected to change the demand for products as explained above. Option 1 will therefore probably have a direct impact on the consumer's choice and on prices of products. It is worth mentioning two sub-groups of consumers in this regard the elderly as well as handicapped people. Though data is not available in this concern, it could be that these groups are of interest to manufacturers as some electric functions could be beneficial in easing everyday actions and in ensuring barrier-free access for handicapped individuals. It is however assumed that for the elderly, most individuals will either have sufficient resources to purchase such products even if a price increase is expected, or would have not considered such a purchase to begin with, in light of the higher price in comparison with conventional products. It is also possible that in these cases, individuals would opt for retrofitting existing products anyway, as openings in their own residence are to be fitted which shall exist to begin with. As for handicapped individuals, there is no data concerning the purchase of such products for private use and thus it is impossible to estimate if this demand would change. In parallel, access for the handicapped to public buildings is assumed to be ensured in most countries by legislation, at least in buildings above a certain size – thus the choice between conventional and non-conventional is not expected to change and thus accessibility is not expected to be hampered in light of a change in prices.
- **Health:** Impacts on health depend on the presence of RoHS substances in windows and doors and mainly in non-electrical parts. As phase out is expected to occur anyway (although possibly at a somewhat slower speed in the case where W&D are excluded from the scope of RoHS), such impacts are expected to remain the same in their range with a small chance of being distributed differently over time.

To conclude, social impacts are expected to occur to some extent as a result of the inclusion of windows and doors in the scope of RoHS, and to affect consumers with a small likelihood of temporary impacts on health.

3.7 Summarised Comparison of Options

The results of the analysis of the various indicators relevant to environmental, economic and social impacts are summarised in Table 3-1 below.

Table 3-5: Comparison of Options

| Impact indicators | Option 1: Business as usual | Option 2: Exclusion from the scope of RoHS |
|--|-----------------------------|--|
| Environmental indicators | | |
| Use of RoHS substances in the manufacture of W&D with electric functions | = | - |
| Emissions of RoHS substances during the life cycle, with a focus on the waste phase | = | = |
| Energy use | = | = |
| Economic indicators | | |
| Possible changes to market structure (including wider impact on trade with non-EU countries) – mainly relevant where components are imported | = | = |
| Impacts to manufacturing costs | = | =/+ |
| Impacts across the supply chain | = | =-/ |
| Possible impacts on consumers (product quality and availability) | = | + |
| Social indicators | | |
| Impacts on employment | = | = |
| Impacts on consumers | = | + |
| Impacts on health | = | = |
| Annotation Used | | |
| +++ Substantial positive effect | | |
| ++ Positive effect | | |
| + Slight positive effect | | |
| = No effect | | |
| - Slight negative effect | | |
| -- Negative effect | | |
| --- Substantial negative effect | | |
| ? Unknown effect | | |

In relation to the overall policy objective of RoHS 2, namely *“to contribute to the protection of human health and the environment, including the environmentally sound recovery and disposal of waste EEE”*¹²³, the discussion above shows that including windows and doors with electric functions in RoHS 2 may have a small contribution to this objective. Inclusion in scope is expected to have small environmental benefits in terms of supporting the phase-out of RoHS substances. These benefits are assumed to be small as phase-out shall probably occur in part in any case due to the reliance of the industry on suppliers for whom the windows and doors sector is not the predominant client. Some economic benefits may also be expected should a shift towards retrofitted products occur (though this would mean that less products fall in scope and thus result in a reduction of all other impacts). In parallel, costs are expected both for manufacturers and for consumers. For manufacturers, costs related to RoHS are mainly associated with the need to document compliance of products (redesign and phase-out costs are assumed to occur regardless of RoHS for the most part). Costs that may incur in light of a shift from integrated products to retrofitted products would be expected to be shifted down to consumers. As retrofitting is already common, it is understood that these costs are acceptable to clients.

Though it is difficult to estimate if total costs would be higher than total benefits, the consultants do not estimate that costs would be significantly larger than possible benefits, all the more as it is understood to be acceptable that manufacturing products with a lower impact on the environment are to create some costs. Additionally, it is assumed that this would still be in line with the objectives of RoHS as other EEE manufacturers are assumed to have dealt with (or to be dealing with) similar costs in order to comply. The fact that at least part of the environmental benefit is to incur regardless of the necessity of products to comply with RoHS is a result of compliance of other manufacturers with the Directive in the past and in the future. In this sense granting exclusion to the manufacturers of windows and doors would also create a less fair distribution of costs between the differing manufacturers of EEE. As for costs for consumers, windows and doors with electric functions are still understood to be a product consumed by a public that can afford products that are more expensive. If compliance is expected to create significant costs for conventional products, it can be assumed that industry would shift to retrofitting in order to avoid possible risks to the development of this market.

3.8 Summary and Recommendation

Exclusion by adjustment of Article 2(4) of the RoHS Directive¹²⁴ would at present solve the sector problems and ease the cost and administrative burden for SMEs in the windows and doors industry. However, in such a case it has to be kept in mind that other product groups may exist that are to carry the burden of RoHS substance phase out. This would also be an incentive for further product groups with similar

¹²³ 2011/65/EU, Article 1

¹²⁴ A sub-option could be the exclusion of a specific group of W&D with electric function.

problems to lobby for exclusion from RoHS. An exclusion of windows and doors with electric functions would bring upon new requests for exclusion, possibly decreasing environmental benefit of other product groups in the long-term, which is not reflected in the comparison of the two options by its own.

An inclusion of windows and doors in the scope of RoHS as described in the baseline option (without any specific exemptions in place) might lead to a change in product portfolio, with few (if any) products expected to disappear but with a potential change in product in terms of installation and sales (two products instead of one). The costs of products may rise due to the reduced integration of the components. However, as exemptions could be requested to solve specific problems (such as unintentional presence of RoHS substances in recycled content not related to design of electrical components), it is also assumed that with sufficient time industry should be able to come to terms with compliance. As industry still has over four years before coming into scope, it is reasonable to assume that in this timeframe it is still possible to locate the actual areas where substitutes are not available, not reliable or would cause more environmental costs than benefits. Thus, sufficient time is available to conclude where exemptions are needed (at least three years) and to request the relevant exemptions (at least 18 months before coming into scope).

Based on this analysis, it is recommended to leave windows and doors with electric function in the scope of the directive.

3.9 References

- BIOIS & ERA (2012) BIO Intelligence Service and ERA Technology (2012): Measures to be implemented and additional impact assessment with regard to scope changes, pursuant to the new RoHS Directive, Final Report prepared for the European Commission, DG ENV, Retrieved from: http://rohs.biois.com/documents/RoHS_II_IA_Final_Report.pdf; Automatic doors and gates Factsheet, retrieved from: <http://rohs.biois.com/product-group-factsheets>
- EU COM (2012) European Commission (2012), RoHS 2 Frequently Asked Questions (FAQ) Document, available under http://ec.europa.eu/environment/waste/rohs_eee/pdf/faq.pdf, last accessed 18.12.2014
- EU COM (2014) European Commission (2014), Report from the Commission to the European Parliament and the Council as foreseen in Article 67(1) of Regulation (EU) 305/2011 EN, Brussels, 7.8.2014, COM(2014) 511 final; <http://ec.europa.eu/transparency/regdoc/rep/1/2014/EN/1-2014-511-EN-F1-1.pdf>
- EU Parliament (2000) European Parliament (2000), Directive 2000/53/EC on end-of life vehicles; <http://eur-lex.europa.eu/legal-content/EN/TXT/PDF/?uri=CELEX:02000L0053-20130611&qid=1405610569066&from=EN>
- EU Parliament (2002) European Parliament (2002), Directive 2002/91/EC on the energy performance of buildings; <http://eur-lex.europa.eu/legal-content/EN/TXT/PDF/?uri=CELEX:32002L0091&from=EN>
- EU Parliament (2006) European Parliament (2006), Regulation (EC) No 1907/2006 concerning the Registration, Evaluation, Authorisation and Restriction of Chemicals (REACH); latest consolidated version available under <http://old.eur-lex.europa.eu/LexUriServ/LexUriServ.do?uri=CONSLEG:2006R1907:20140410:EN:HTML>
- EU Parliament (2010) European Parliament (2010), Regulation (EU) No 995/2010 laying down the obligations of operators who place timber and timber products on the market; <http://eur-lex.europa.eu/legal-content/EN/TXT/PDF/?uri=CELEX:32010R0995&from=EN>
- EU Parliament (2011) European Parliament (2011), Regulation (EU) No 305/2011 laying down harmonised conditions for the marketing of construction products and repealing Council Directive 89/106/EEC; <http://eur-lex.europa.eu/legal-content/EN/TXT/PDF/?uri=CELEX:32011R0305&from=en>
- EuroWindow (2014a) EuroWindow (2014a): Interview held on 05.12.2014 with Frank Koos, Ulrike Döbel (EuroWindow General Secretariat), Britta Hougaard (JELD-WEN, Leader of Task Group 11 "RoHS II" and Member of FEMIB Management Council) and Joachim Oberrauch (Finstral, Chairman EuroWindow and President EPW).
- EuroWindow (2014b) EuroWindow (2014b): Presentation provided for the interview per e-mail on 05.12.2014.
- EuroWindow (2014c) EuroWindow (2014c): Summary of supplier survey regarding RoHS compliance submitted by the European door manufacturer on 08.12.2014.
- JRC-IPTS (2012) Joint Research Centre's Institute for Prospective Technological Studies (JRC-IPTS) (2012): Green Public Procurement Windows and External Doors –

- DRAFT, Technical Background Report; Report for the European Commission – DG-Environment, 2012;
<http://susproc.jrc.ec.europa.eu/windows/docs/Technical%20background.pdf>
- Oeko-Institut (2014) Oeko-Institut e.V Institute for Applied Ecology: Gensch, C.-O.; Baron, Y.; Diesner, M.-O. (2014), Additional Input to the Commission Impact Assessment for a Review of the Scope Provisions of the RoHS Directive Pursuant to Article 24(1), Report for the European Commission DG Environment under Framework Contract No ENV.C.2/FRA/2011/0020, Final Report;
http://rohs.exemptions.oeko.info/fileadmin/user_upload/reports/20140601_2_RoHS_Scope_Review_report_final.pdf
- PE Europe et al. (2004) PE Europe GmbH, Institut für Kunststoffkunde und Kunststoffprüfung (IKP), Institut for Produktudvikling (IPU), DTU, RANDA GROUP (2004): Life Cycle Assessment of PVC and of principal competing materials Commissioned by the European Commission, July 2004;
http://ec.europa.eu/enterprise/sectors/chemicals/files/sustdev/pvc-final_report_lca_en.pdf
- RPA and Tecnalía (2013) RPA and Tecnalía (2013), Study on specific needs for information on the content of dangerous substances in construction products, Final Report prepared for DG Enterprise & Industry 31st October 2013; retrieved from http://ec.europa.eu/enterprise/sectors/construction/studies/index_en.htm#h2-4

4.0 Refurbishment of Medical Devices in the Context of RoHS

4.1 Abbreviations

| | |
|----------|--|
| Cd | Cadmium |
| COCIR | the European Coordination Committee of the Radiological, Electromedical and Healthcare IT Industry |
| Cr VI | Hexavalent chromium |
| CT / CAT | Computerised tomography / computerized axial tomography |
| DHR | Device History Record |
| EDMA | European Diagnostic Manufacturers Association |
| Eucomed | Trade association representing the medical technology industry in Europe. Members include national and European trade and product associations as well as medical technology manufacturers |
| GRP | Good Refurbishment Practice |
| Hg | Mercury |
| IVD | In vitro diagnostic [medical devices] |
| MD | Medical devices |
| MRI | Magnetic resonance imaging |
| OEM | Original Equipment Manufacturer |
| Pb | Lead |
| PBB | Polybrominated biphenyl |
| PBDE | Polybrominated diphenyl ethers |
| PCB | Printed circuit board |

4.2 Procedural Issues

In 2011, the European Coordination Committee of the Radiological, Electromedical and Healthcare IT Industry (COCIR) submitted a request for an exemption for:

“Reuse of parts from medical devices including X-ray tube components in new X-ray tube assemblies”

This request was evaluated in 2012¹²⁵ and led to Commission Delegated Directive 2014/15/EU of 18.10.2013, amending Annex IV of RoHS 2, through the addition of Ex. 31, which is currently in force, allowing the use of:

“Lead, cadmium and hexavalent chromium in reused spare parts, recovered from medical devices placed on the market before 22 July 2014 and used in category 8 equipment placed on the market before 22 July 2021, provided that reuse takes place in auditable closed-loop business-to-business return systems, and that the reuse of parts is notified to the consumer. Expires on 21 July 2021.”

In 2013, FEI, a manufacturer of electron microscopes, requested a similar exemption, (proposing as an alternative that Ex. 31 be reformulated) to allow the presence of Pb and Cr VI products made available in the EU originating from refurbishment facilities for electron microscopes and their accessories. COCIR participated in the stakeholder consultation of this request, among others resulting in a request, supported by both FEI and COCIR, that the exemption be extended to all RoHS regulated substances. A further change requested was that the exemption be reformulated to support the use of refurbished parts recovered from the global market and placed on the EU market. The evaluation¹²⁶ resulted in a positive recommendation to grant an exemption. The EU Commission is still to decide if to grant the exemption as recommended.

The path to use the exemption procedure, as a means for possibly resolving the problems of the refurbishment practices with the RoHS Directive, has been questioned in light of the wide and general scope of an exemption suited to tackle such aspects. The European Commission thus requested the current study be prepared to substantiate the scope of such problems on a more comprehensive level and to establish the scope of impacts (environmental/ economical /social) that different policy options aimed at solving such problems may result in.

In the course of this study, stakeholders were notified of the objectives of the study and of the possibility to contribute information to be evaluated as part of this review. A number of stakeholders expressed their interest in this project, including COCIR, European Diagnostic Manufacturers Association (EDMA) & Eucomed and FEI. Such stakeholders received a first questionnaire (see Appendix A.2.0, outlining the various aspects of interest for the review). A targeted stakeholder meeting was held with these stakeholders as well as with representatives of some of their members on 27 November 2014 in Brussels to allow an open discussion of various aspects. Following the meeting, some of the participants submitted additional information for use in the evaluation. Information obtained through these stages as well as

¹²⁵ For further detail see Section 7 of the evaluation report under:
http://rohs.exemptions.oeko.info/fileadmin/user_upload/RoHS_VI/20130412_RoHS2_Evaluation_Pr oj2_Pack1_Ex_Requests_1-11_Final.pdf

¹²⁶ For further detail see Section 6 of the evaluation report under:
http://rohs.exemptions.oeko.info/fileadmin/user_upload/ROHS_Pack5/201410_RoHS_Ex_Pack5_Final_Report_final.pdf

information available from the first two evaluation processes, has been the basis for preparing this report.

4.3 Problem Definition and Background

As an outcome of the RoHS Recast (Directive 2011/65/EU – RoHS 2), medical devices (category 8 of Annex I) have been included in the scope of articles that need to comply¹²⁷ with the Directive requirements. This includes complying with the RoHS substance restrictions as required by Article 4(1) of the Directive:

“Member States shall ensure that EEE placed on the market, including cables and spare parts for its repair, its reuse, updating of its functionalities or upgrading of its capacity, does not contain the substances listed in Annex II”

Products of the medical device manufacturing sector can be categorised into a few sub-groups, according to how they are impacted by the RoHS substance restrictions; this includes:

- New devices;
- Device parts; and
- Previously owned devices.

As placing on the market is defined in Article 3(12) as “making available an EEE on the Union market for the first time” it is thus understood that both new devices as well as spare-parts need to comply with the substance restrictions at the time they are first placed on the market.

In comparison, second hand devices and second hand parts, are in general not required to re-comply; their compliance is based on the substance restrictions in force when they were originally placed on the market (i.e., as new products). Nonetheless, as shall be explained in the following, in the case of previously owned medical devices which are refurbished, in some cases a refurbished device will be required to comply with the RoHS substance restrictions at the time it is made available on the market, regardless of the compliance of the original device at the time first sold.

For example, this is the case of a product first sold in 2010 on a non-EU market (as a new product), refurbished and then sold as a refurbished product on the EU market in 2015. Since the sale in the EU is the first time the device is placed on the Union market, the product is required to comply with the substance restrictions relevant in 2017 for this product category, regardless of compliance of the new product in 2010.

In the case of medical devices, the various product categories need to comply with the substance restrictions starting 22 July 2014 (general) and 22 July 2016 (in-vitro diagnostics). In this sense, regardless of what market the product was first sold on, before these dates all medical devices were compliant with RoHS because the use of

¹²⁷ A product is considered compliant if it either a) does not contain any RoHS restricted substances above the %/weight specified in Annex II of the Directive or b) if the remaining use of RoHS restricted substances in the relevant components is allowed through an existing exemption listed in Annex III of the Directive, at the time the end-product is placed on the EU market.

RoHS substances was not yet restricted in these products. The same article placed on an EU market can be refurbished and resold on the EU market, as the substance restrictions only apply at the first time that EEE is placed on the EU market (when such a device is resold, compliance is related to this first time compliance). Regardless of the presence of RoHS substances in a refurbished device first placed on the EU market, it can be resold on this market without being required to retroactively comply with the RoHS substance restrictions.

Stakeholders have communicated that in the medical sector, refurbishment is often carried out on a global basis (one facility refurbishes all medical devices of a certain model, regardless of where they were first sold and regardless of where they are destined to be resold). Thus concerns have been raised that enforcement of the current RoHS legal text could result in costs higher than the benefits thereof.

Though the benefits of eliminating the use of RoHS substances in refurbished medical devices remain to be quantified, it is possible that compliance with the RoHS substance restrictions may result in significant costs. In this regard, the consultants have identified a scenario, in which the costs of compliance could be significant enough to justify an adjustment of the RoHS legal text and/or annexes for this product category:

- If the compliance of refurbished medical devices with the Directive results in environmental burdens, in terms of medical devices (or parts) reaching end-of-life early (and manufacture of new articles as replacements), which are significantly higher than the benefits expected from the compliance of these devices with the RoHS restrictions.

The use of both refurbished medical devices and refurbished parts recovered from medical devices could be affected in the case that the RoHS Directive would remain unchanged. Thus, in the following parts of this review, the various aspects related to these product groups is to be discussed. Besides product groups to be affected, it is also important to point out that based on information provided by the medical sector¹²⁸, at present refurbishment practices are practiced for:

- Imaging equipment such as Magnetic Resonance Imaging (MRI) devices, Computer Tomography (CT) devices, etc. (refurbishment practices well established);
- In-vitro diagnostic devices (refurbishment practices well established);
- Patient monitoring devices (refurbishment practices are starting to develop).

It is possible that refurbishment practices are established or in development for other medical devices, however this has not yet been confirmed by stakeholders. Nonetheless, the consultants conclude that both Cat. 8 (general medical devices) and Sub-Cat. 8 In-vitro (in-vitro diagnostic devices) should be taken into consideration in

¹²⁸ Medical Sector (2014), Protocol of Targeted Stakeholder Meeting concerning Medical Refurbishment in the Context of RoHS, held in Brussels, Belgium, on 27 November 2014.

any decisions made to resolve the current problems, related to refurbishment in the context of RoHS.

It should further be noted that a manufacturer of electron microscopes (FEI¹²⁹) has mentioned in the past that it has similar refurbishment practices in place and would be similarly impacted by the current terms of the directive. The TOR for this project required a review for medical refurbishment on the context of RoHS, and thus other product groups shall not be discussed. However it should be noted that the aspects raised in this review are also relevant for electron microscopes falling under sub-category 9 “industrial monitoring and control instruments” and possibly also for other products designed for long life and being low volume – high value products.

4.4 Background

Though refurbishment and resale of second hand products is common in various EEE sectors, products of the medical sector have certain characteristics which are of importance where compliance with the RoHS Directive is concerned:

- Medical devices for which refurbishment practices are common, often have a **long planned service life** and are thus more robust in design, to enable a longer product life-time. Refurbishment operations have therefore developed in the medical sector as a means to ensure that such devices operate throughout their planned service life, or beyond. EDMA & Eucomed¹³⁰ detail that *“the typical life of a new IVD instrument within a given laboratory is 5 to 7 years, at which time the laboratory will often upgrade its system for a newer or different model. Given that the instrumentation is usually designed to operate much longer, when it is removed from the laboratory, it is typically refurbished and placed into another lab. Clinical laboratory blood analysers, medical optics lab analysers, blood bank analysers and point of care handheld bedside analysers are examples of IVDs which may be allotted typical lifetimes (ranging upwards from 7 years) however, may last far longer when refurbished. Refurbished devices can be out in the field for 15-20 years (and there are some concrete examples of well-maintained instrumentation in the field already 30 years).”* In the targeted stakeholder meeting, participants agreed that for medical devices and electron microscopes, equipment and parts could remain in circulation for 10-20 years if refurbishment practices are not limited.¹³¹
- Furthermore, products can often be described as **“low volume – high value”**, meaning that devices are manufactured in low numbers and have a high market value (cost).¹³²

¹²⁹ See Information posted on RoHS Evaluation Web-site, available under: <http://rohs.exemptions.oeko.info/index.php?id=206>

¹³⁰ EDMA & Eucomed (2014a), EDMA & Eucomed Response to Questionnaire Concerning Impacts on Refurbishment, submitted 5.12.2014 per email;

¹³¹ Op. cit. Medical Sector (2014)

¹³² Op. cit. Medical Sector (2014)

- The former is an important aspect, as a consequence to these characteristics, manufacturers of the medical sector have developed refurbishment practices on a **global basis**, to ensure the economic feasibility of these operations. Logistically, global operations also allow bridging the differences between supply and demand for refurbished products in certain areas. In the EU, the supply is lower than the demand for such products, whereas the global operation allows sourcing additional devices from outside the EU. A manufacturer shall usually have a single global facility processing the refurbishment of all devices of a certain model. For example EDMA & Eucomed's¹³³ members, who refurbish, have one or several refurbishment facilities which serve a global market.

From the targeted stakeholder meeting, it is understood that in the course of refurbishment in the medical sector, second hand devices are first inspected to establish that they are still operative, followed by performing various refurbishment activities as required to allow resale of the device. In some cases parts are replaced with new parts, whereas in other cases parts which are still functional shall be subjected to refurbishment actions to allow them to remain in use – i.e. disinfection and system cleaning / aesthetic refurbishment / reconfiguration and software updates etc.¹³⁴

As such parts may remain in circulation 10-20 years, some of them may contain RoHS substances (since at the time placed on the market they were not required to comply with the substance restrictions). In some cases, as shall be explained below, this may create obstacles for the reuse of products in terms of compliance with the RoHS Directive.

4.4.1 Legal Background

Medical devices need to comply with the substance restrictions stipulated in Article 4(1), consequence to Article 4(3): “*Paragraph 1 [i.e., Article 4(1)] shall apply to **medical devices... which are placed on the market from 22 July 2014; and to in vitro diagnostic medical devices which are placed on the market from 22 July 2016***”.¹³⁵

Article 4(4), provides an exclusion from the substance restrictions for “*cables and spare parts for the repair, the reuse, the updating of functionalities or upgrading of capacity of... (b) medical devices placed on the market before 22 July 2014; (c) in vitro diagnostic medical devices placed on the market before 22 July 2016;... (f) EEE which benefited from an exemption and which was placed on the market before that exemption expired as far as that specific exemption is concerned.*”¹³⁶

¹³³ Op. cit. EDMA & Eucomed (2014a)

¹³⁴ Op. cit. Medical Sector (2014)

¹³⁵ See Directive 2011/65/EU under <http://eur-lex.europa.eu/legal-content/EN/TXT/?uri=CELEX:32011L0065>

¹³⁶ See Directive 2011/65/EU under <http://eur-lex.europa.eu/legal-content/EN/TXT/?uri=CELEX:32011L0065>

Refurbishment is not mentioned in the context of Article 4(4). However recital 20 of the Directive states that “As product reuse, refurbishment and extension of lifetime are beneficial, spare parts need to be available”. Refurbishment is not defined in the Directive. COCIR’s Green Paper on Good Refurbishment Practice (GRP) provides a possible definition as well as requirements established by the medical imaging sector, both of which are detailed in Section 4.7 below.

Furthermore, exemptions are available in Annexes III and IV permitting the temporary use of RoHS substances in certain applications, some of which are relevant for medical devices.

The above mentioned articles provide the legal framework for understanding what medical products and parts need to comply with the RoHS Directive.

A further aspect of relevance to compliance concerns the ownership of a device. The RoHS Directive makes a distinction between articles placed on the Union market for the first time and articles made available on the Union market through secondary market operations, i.e., marketing of previously owned products or of products made available through renting and leasing operations. (See Articles 3(11) and 3(12) of RoHS 2).

In light of the formulation of Article 4(1), only articles placed on the market for the first time need to comply with the substance restrictions. However, as a consequence of the reference to the Union market in Articles 3(11) and 3(12), it is to be noted that secondary market operations of products placed on the EU market differ from those of products placed on other-than-the-EU market where the substance restrictions are concerned. The compliance requirement applies when the product is first placed on the EU market, so that though a device previously sold in the EU will be seen as compliant for life, a product first sold outside the EU will need to prove compliance with the Directive requirements relevant at the time it is placed on the market. Compliance with EU regulation at first sale, expressed through CE marking¹³⁷, is irrelevant, meaning that if the requirements have changed, the product will need to be demonstrated as compliant or will be denied market access. In other words, whereas a product placed on the EU for the first time, may be refurbished and resold on the EU market, other products placed on external markets will be denied market access from 22 July 2014 unless compliance with the substance restrictions can be proven.

Furthermore, spare parts and cables also need to comply with the RoHS substance restrictions the first time they are placed on the EU market; however, here an exclusion applies depending on the product in which the spare-part is to be used. Article 4(4) allows the use of non-compliant spare parts¹³⁸ in products where the

¹³⁷ As defined under Regulation (EC) No 765/2008a, Article 2(20): “marking by which the manufacturer indicates that the product is in conformity with the applicable requirements set out in Community harmonisation legislation providing for its affixing”.

¹³⁸ Cables are not referred to in this review separately, as they are not manufactured by the medical sector, however it should be noted that Article 4(4) also permits the manufacture and use of non-compliant spare parts for repair in the cases specified in items a-f.

restrictions did not apply to such products at the time placed on the market (either as the category was not in scope – items b and c – or as an exemption was valid to permit the use of a RoHS substance – item f). Here too, such parts can be used for repair of articles placed on the EU market in the past and legally not conform to the current substance restrictions. However the same product cannot be repaired with such parts, if it was first placed on an extra-EU market and is only to enter the EU market after repair with non-compliant parts. As medical devices are refurbished globally, this would mean that such operations must either be separated (i.e. performed for EU devices and non-EU devices at different locations), or that logistic systems must be applied to allow tracking and singling out of products first placed on the EU that can be repaired with non-compliant spare parts and resold in the EU. These are the only products in which non-compliant spare parts can be used for repair, both if they are newly manufactured spare parts or if they are refurbished (2nd hand) spare parts¹³⁹. This also means that refurbished spare parts, despite compliance at the first time they were placed on the EU market, are retroactively restricted for use if the substance restrictions have changed at the time they are to be used in the assembly of a new product at a later time. In this regard, some spare-parts are not “placed on the market”, in the sense that they are used by the OEM without an actual transaction taking place. However, spare-parts placed on the EU market, will be CE marked and in compliance with RoHS and would thus normally benefit from not having retroactive compliance requirements. This implies that the legal text is inconsistent in this regard.

Article 3(27) provides a legal definition for spare parts from which it can be interpreted what parts would benefit from the Article 4(4) exclusion: “*‘spare part’ means a separate part of an EEE that can replace a part of an EEE. The EEE cannot function as intended without that part of the EEE. The functionality of EEE is restored or is upgraded when the part is replaced by a spare part*”. This definition means that only parts that are relevant for the proper function of an EEE could benefit from the Article 4(4) exclusions. It also means that a decorative refurbished part, which will not affect the functionality of the EEE, cannot be reused for repair of devices to be made available on the EU, despite this being a contradiction to the unlimited secondary market operations granted a product compliant at the time first placed on the market.

Furthermore, in contrast to “*spare parts*”, neither “*components*” nor “*parts*” are defined in the RoHS legal text and are thus treated differently. The RoHS 2 FAQ¹⁴⁰

¹³⁹ The exemption request evaluation that led to Ex. 31 discussed if both new and used parts could benefit from Article 4(4). Though the report interpreted at the time that this Article was only available for use of RoHS substances in new spare parts, this was only an interpretation which is not legally binding. As Article 4(4) does not specify what kind of spare parts (used, new), it is understood that this is left open to interpretation, with only the devices in which such parts can be used being specified.

¹⁴⁰ See Q7.3 “Do components have to comply with RoHS 2? RoHS 2 provides that EEE has to meet the requirements of the Directive. Since equipment consists of different components, the EEE itself can only meet the substance requirements if all its components and parts meet the substance restriction requirements of RoHS 2, including non-electronic or non-electric components like fasteners or the plastic case of a desktop computer. Therefore components being used in finished EEE or for repair or upgrade of used EEE, which is in the scope of RoHS 2 must meet the substance restrictions according

document clarifies that components are not to be understood as spare parts and that they need to comply. As the consultants understand spare-parts to be a sub-group of parts, it is assumed that some parts would need to comply (for example parts not providing or affecting the functionality of the EEE) and some would not in light of their influence on functionality.

To summarise, it is understood that devices always need to comply with the substance restrictions relevant at the time they are first placed on the EU market. This includes the case of a refurbished product first placed on a non-EU market in which all non-compliant spare-parts used in its refurbishment were first legally placed on the EU market. Though the device is compliant aside from the refurbished parts already placed in the past on EU markets, it loses its compliance through the use of these parts. The device would need to replace these parts with new compliant parts to establish compliance for its first placement on the EU market. In comparison, for spare parts, compliance would depend on the status of the product in which they are intended to be used, and on the RoHS restrictions that applied at the time it was first placed on the EU market. All spare-parts, compliant or not, can be used for repair of a product compliant when first placed on the EU market. However, only spare parts compliant with the RoHS substance restrictions at the time of use can be assembled into products that need to comply with substance restrictions at the time made available on the EU market, and thus have a limited access to the market in secondary operations. See decision trees provided in Figure 4-1 and Figure 4-2 below to further clarify in what cases compliance is required retroactively.

to Art. 4 but do not need CE marking. Components sold as a stand-alone components or if produced to be used in a product benefiting from an exclusion do not have to be CE marked and do not have to comply with the substance requirements.” Cited from EU COM (2012), European Commission, RoHS FAQ Document, last updated 12.12.2012, last accessed 10.12.2014, available under http://ec.europa.eu/environment/waste/rohs_eee/pdf/faq.pdf

Figure 4-1: Can a Refurbished Device be Placed on the EU Market?

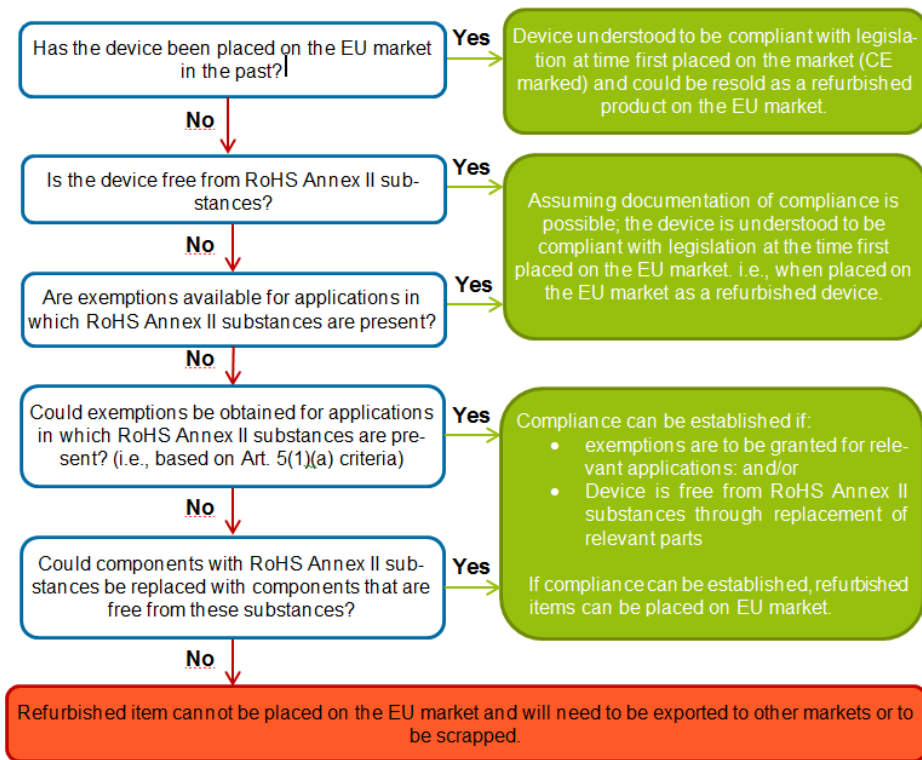
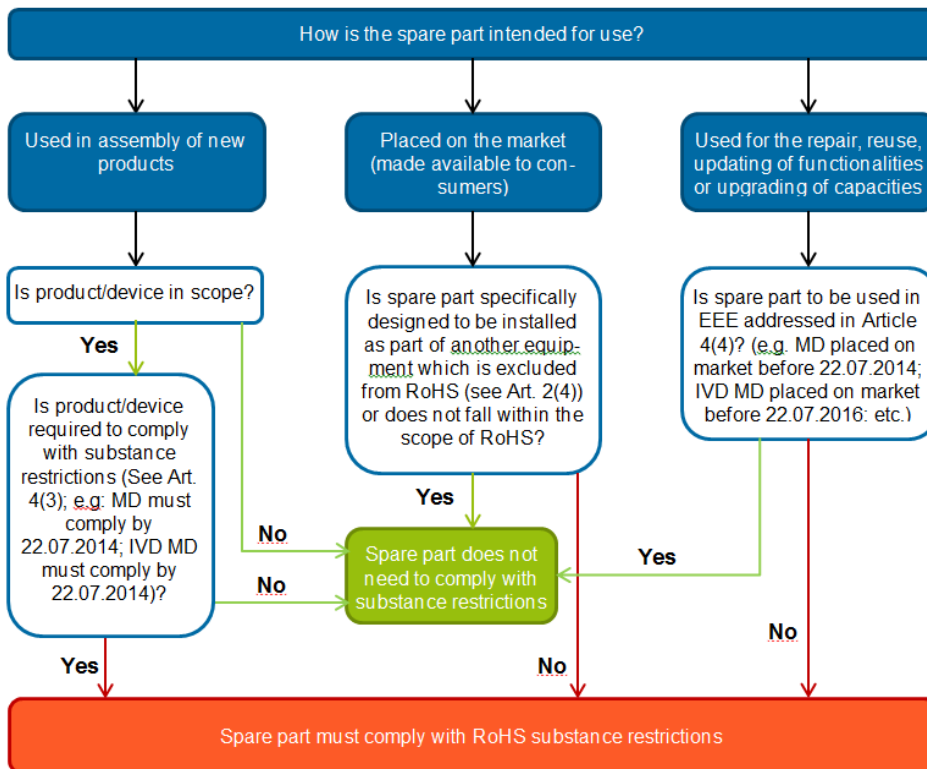
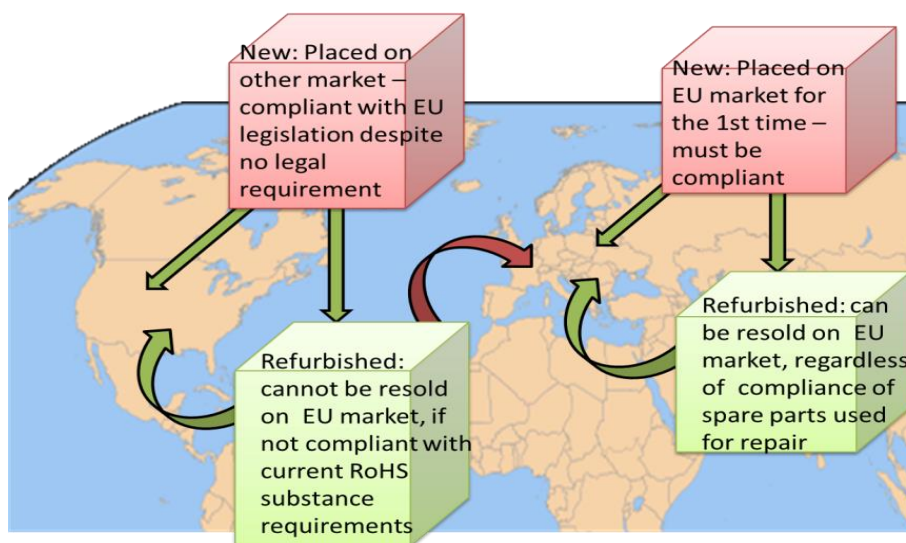

Figure 4-2: Compliance of Spare Parts



As medical devices are often refurbished and resold as second hand products, this aspect is particularly of concern when such products are refurbished outside the EU and then imported and placed on the EU market (as illustrated in Figure 4-3). Certain limitations shall also apply in the case of resale of parts, as explained above. Thus concern has thus been raised by medical manufacturers, that these aspects may impact refurbishment operations in a way that could in some cases lead to adverse impacts. Such impacts and possible solutions to these problems are the focus of the current review.

Figure 4-3: Illustration: RoHS Substance Restrictions and the Possibilities of Placing a Product on the Market



Notes:

- Red box / Green Box --> new devices / 2nd hand (refurbished) device)
- Red arrow / green arrow --> compliance with RoHS substance restrictions required when made available on the market / compliance established when first placed on the market sufficient for secondary market operations in the EU market.

Source: Own illustration

4.5 Objectives

The objective of both the RoHS recast proposal (COM (2008) 809 final) as well as RoHS 2 (2011/65/EU) is *“to contribute to the protection of human health and the environment, including the environmentally sound recovery and disposal of waste EEE”*.¹⁴¹

The purpose of this study is to look at the impacts of the RoHS substance restrictions on refurbished medical devices and parts where the RoHS 2 legal text is applied as is, compared to an alternative in which adjustments are to be made to allow all CE marked medical devices to enjoy access to the EU market without needing to re-comply with the substance restrictions when resold on the EU market. Policy options

¹⁴¹ Directive 2011/65/EU, Article 1

are thus evaluated according to the ability to reach the abovementioned overall objective of the RoHS Directive, as well as whether they lead to the following scenario:

- If the compliance of refurbished medical devices with the Directive results in environmental burdens, in terms of medical devices (or parts) reaching end-of-life early (and manufacture of new articles as replacements), which are significantly higher than the benefits expected from the compliance of these devices with the RoHS restrictions.

4.6 Policy Options

The policy options analysed are the following:

Option 1 (Business as usual scenario): As per the original RoHS 2 legal text, refurbishment shall not be explicitly supported through adjustments of the RoHS legal text. *This scenario is investigated in order to understand the range of impacts if refurbished articles were in scope – this is understood to be a baseline scenario which shall provide a reference for the two other scenarios.*

Option 2 (Exemption 31 scenario): Refurbishment allowed through exemptions that need to be renewed from time to time. *This scenario represents the current state of the Directive as amended by Commission Delegated Directive 2014/15/EU of 18 October 2013 with the addition of Ex. 31 to Annex IV.*

Option 3 (Exclusion 4(7) scenario): Refurbishment provided through an adaptation of Article 4. *This scenario is investigated in order to review how a permanent solution would affect impacts.*

A further Sub-Option in which the Exemption 31 scenario is implemented temporarily with the Exclusion 4(7) scenario implemented subsequently shall be discussed shortly on the basis of results for the first three options. The importance of this Option has been raised by stakeholder in light of Option 3 requiring a transition period in light of the time needed to implement changes to the Directive legal text.

Furthermore, policy options shall be analysed referring to aspects related to global refurbishment practices.

4.7 The Baseline

Within COCIR's Green Paper on Good Refurbishment Practice (GRP)¹⁴², refurbishment is defined as: *“a systematic process that ensures safety and effectiveness of the medical equipment without significantly changing the equipment's or system's performance, safety specifications and/or changing intended use as in its original registration”*. Any upgrades processed during GRP refurbishment are thus required to perform in a manner consistent with the original product specifications and service procedures defined by the manufacturer for that equipment or system.

¹⁴² COCIR et. al. (2009), COCIR, JIRA, MITA, Green Paper on Good Refurbishment Practice (GRP) for Medical Imaging Equipment.

Refurbishment can be divided in to two types:

- Refurbishment performed by the OEM;
- Refurbishment performed by 3rd parties.

One advantage of OEM refurbishers concerns their access to the original specifications of a certain device as well as to documentation provided by suppliers at time of manufacture, regarding the use of certain substances. OEMs may further be supported by the original suppliers of some components in the refurbishment of certain parts. In this sense they often offer refurbished products, which are said to be “as good as when new”¹⁴³. Little information is available concerning 3rd party refurbishers and it remains to be determined how relevant aspects discussed in this review are for such refurbishers.

Good Refurbishment Practices are explained¹⁴⁴ to have certain elementary requirements which equipment must adhere to in order to be qualified and eligible for refurbishment. *“The first key factor for refurbishment qualification is the **intended use** as determined by the manufacturer including its product specifications. Devices intended for single use or designed as not eligible for refurbishment should not be refurbished. The second key factor for refurbishment qualification is that it is good practice to refurbish only **equipment that still meets the original standards at time of first placement**. That means used medical equipment that does not meet, or cannot be refurbished to meet, these original standards should neither be refurbished nor utilized any more. The **lifetime of medical equipment and serviceability aspects** are also key requirements to determine qualification for refurbishment. Medical equipment is designed and manufactured to be used for a planned lifetime. When the healthcare service provider puts the product into service, maintenance procedures defined by the original manufacturer ensure that the intended levels of safety and performance are preserved. The end of planned lifetime is generally reached when original manufacturer service, spare parts and components are no longer available for the product.”*

The GRP Green Paper specifies that the most important aspects to be considered in reutilizing used medical equipment are quality, performance, safety and intended use. The document thus describes refurbishment process steps designed to make sure that any system that will be refurbished according to GRP will have the same quality, performance, safety, and intended use - including full warranty and service - as when it was new. These steps regard not only the refurbishment activities but also activities that take place before a device enters the refurbishment pool and after its refurbishment, to enable its being made available on the market. The steps are presented in Table 4-1 below and shortly described thereafter.

¹⁴³ Op. cit. COCIR et. al. (2009)

¹⁴⁴ Op. cit. COCIR et. al. (2009)

Table 4-1: GRP Refurbishment Practice Process Steps

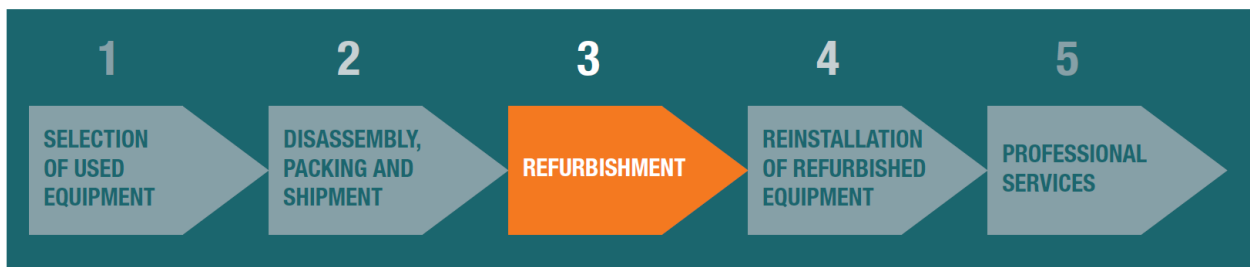

Source: COCIR et al. 2009

1. **Selection of used equipment for refurbishment** - Generally, the selection of used equipment is based on the principle that the used system can be refurbished to a system that has the same quality, performance, safety and intended use as when it was new. The equipment is required to fulfil certain criteria such type of equipment; configuration; condition; age, upgradeability and the phase in the life cycle in terms of spare part availability.
2. **Disassembly packaging and shipment** - To avoid any additional risk, the organization that performs refurbishment has to make sure that any system that is to be refurbished will not be damaged during disassembly or shipment. This may include disinfection activities at the place of the disassembly, depending on the kind / type of environment the device was operated in (e.g. emergency room, operating room).
3. **Refurbishment** – this will include a few phases:
 - a. *Cleaning and disinfection*; this is to make sure that any system that will be refurbished will bear no risks regarding infection of any person during or after the refurbishment process;
 - b. *Refurbishment planning* – The required actions to be undertaken through the refurbishment are planned to ensure that they do not create modification that might impair the original identity and approved configuration of the device, meaning that regulatory implications might arise. The system configuration is defined by the refurbisher or according to a customer order – it must be within the scope of the original product registration from the manufacturer, when the system was originally produced and put on the market for the first time. In any case, the system must keep its original identity (e.g. labelling). Throughout the refurbishing process, the Device History Record (DHR) must be continuously updated. Refurbished equipment that does not comply with the original intended use, specifications, and registration has to be treated like unapproved, unregistered medical equipment. In some countries such significant changes through refurbishment are defined as “fully refurbishing” or “remanufacturing”;
 - c. *Cosmetic refurbishment* – Surface treatment and painting are performed as needed, depending on the state if the device;
 - d. *Mechanical and electrical refurbishment and system configuration* – this can include replacement of worn parts; actions to avoid violation of

privacy rules concerning patient data stored on medical equipment; performance of planned updates (such as software); customization through options and accessories within the scope of product registration; Updating of DHR to show evidence that the equipment was refurbished according to the specification of the equipment;

- e. *System check* - Thorough checking of components and subsystems;
 - f. *GRP Declaration and release* – When all necessary actions for refurbishment have been successfully completed, the refurbisher releases the equipment, self declares compliance to GRP (GRP-Declaration) and labels the product accordingly (name & place of the organization and date of refurbishment). The GRP-Declaration is handed over to the final customer as a proof for GRP compliance.
 - g. *Packing and shipment* – process steps for packing and shipment must be identical or equivalent to the process steps for new systems;
- 4. Reinstallation of refurbished equipment** – Equipment processed according to GRP is intended to meet original quality, performance and safety standards, hence it is essential to follow original manufacturer installation procedures including site planning and preparation works. A professional installation is to be carried out and to include start-up and repeated check-up of the system's performance, application training, hand-over of required user documentation and GRP Declaration;
- 5. Professional services** - A buyer or user of GRP-processed equipment can expect after-sale services and support, identical to what is provided for new systems. Therefore, the refurbisher will ensure that professional services and support are provided in the same way as for a new system. i.e., full necessary support provided over the planned lifetime of the equipment. To this end, the warranty shall be equivalent to a new system, original spare parts will be made available, as well as ensuring that maintenance contracts, application training etc. can be provided.

As mentioned in Section 4.3, it is understood that refurbishment is not practiced at present for all medical devices. However, for certain category sub-groups, refurbishment of second hand equipment prior to resale is quite common.¹⁴⁵ A COCIR member reports that up to 10% of its sales volume for medical imaging equipment is comprised of refurbished equipment. Information collected from EDMA & Eucomed's

¹⁴⁵ It should be noted, that electron microscopes have been shown to have similar operations in place as well as similar problems with compliance with the RoHS Directive. The TOR for his project required a review for medical refurbishment on the context of RoHS. However, as also stated above, it should be noted that the aspects raised in this review are also relevant for electron microscopes falling under sub-category 9 "industrial monitoring and control instruments" and possibly also for other products designed for long life and being low volume – high value products.

Members points out that companies who manufacture and refurbish in-vitro diagnostics (IVD) devices sell between 8-25% refurbished devices¹⁴⁶.

In terms of market shares, at a targeted stakeholder meeting held to collect information for this review, COCIR have mentioned that the general turnover of the medical sector is around 100 Billion € per annum, with around 4 Billion € relevant for imaging devices. Participants emphasized that refurbishment operations of OEMs are often operated as separate business units and that estimating the market share and turnover of the medical sector to those relevant for refurbishment would be misleading in this context. EDMA/EUCOMED mentioned in the earlier discussions that the IVD turnover is around 10.6 Billion. COCIR estimate the turnover of refurbished imaging devices in the EU to be around 100-200 Million € and expected to grow in light of the economic situation.¹⁴⁷ This would represent between 2.5% and 5% of the general medical imaging devices turnover and is relevant only for turnover from refurbished medical imaging devices sold in the EU.

The following points were mentioned by COCIR¹⁴⁸ in an earlier document:

- *“The refurbishment of medical equipment accounted for a global revenue of approximately 480 million euros in 2012. Around 74% of revenues are generated in the U.S. and the EU.*
- *In 2013 refurbished medical equipment worth around 130 million euros was sold in the EU.*
- *39% of all refurbished medical equipment is sold in the EU with Germany accounting for 22% of the EU total. In Germany one of every six installed imaging equipment is a refurbished unit.*
- *The refurbishment market is expected to grow in the coming years due to increased confidence by users in the quality of refurbished equipment and to the budget constraints in healthcare purchasing in the EU. RoHS 2 is therefore going to have a greater impact on the refurbishment market in the coming years.*
- *In 2010, €200 million worth of refurbished medical equipment was sold in the EU and 30 – 50% of these were initially sold to users outside the EU. If those units originally sold outside the EU could not be resold to EU users, there would be a shortage of refurbished equipment to EU hospitals worth up to €100 million”.*

EDMA/EUCOMED¹⁴⁹ provide further support for the last point, estimating that the demand for refurbished devices in the EU will likely increase by 5-10% in the next

¹⁴⁶ Op. cit. EDMA & Eucomed (2014a)

¹⁴⁷ Op. cit. Medical Sector (2014)

¹⁴⁸ COCIR (2014b), Impact Assessment of RoHS II on Refurbishment of Medical Equipment Affecting Industry, Environment and EU Patients – Summary, dated 29 April 2014

¹⁴⁹ Op. cit EDMA/EUCOMED (2014a)

year. As the affected products progress through their life cycle and the population ages, the mix of refurbished instruments will increase.

The consultants conclude that on the basis of 39% of refurbished devices being sold in the EU and 30-50% of these initially being sold to users outside the EU, that potentially ~11.7-19.5% of refurbished medical devices sold in the EU may have problems with compliance. In this regard, it should be noted that this is understood to be a worst case estimation, as presumably not all of these products shall exhibit problems with compliance in terms of presence of RoHS substances.

The market for refurbished medical devices is motivated among others by the price of these devices and their ability to allow facilities to provide services at a lower cost. In some cases this allows health facilities to provide a larger capacity of services, at lower costs in comparison to the costs if all devices were bought as new devices. In other cases refurbished devices allow facilities to provide services, which they could otherwise not afford from a budgetary perspective. In this regard EDMA/EUCOMED¹⁵⁰ elaborate that some markets demand the placement of predominantly, if not exclusively, refurbished units, due to price sensitivity. This due to some markets not being able to afford new analysers or larger medical equipment. EDMA/EUCOMED further stated at the stakeholder meeting that purchasers of refurbished medical equipment and instrumentation include health service providers, clinical laboratories and others such as the academic field. Many clinical laboratories, for example, will purchase a new analyser as well as maintain an older model or purchase a refurbished model in order to manage their costs. Laboratories or smaller clinical centres, which need to run a low volume of tests or procedures, would only invest in such second hand equipment. They further mentioned that one manufacturer reports that some markets in Europe rely almost exclusively on refurbished goods to have immediate access to the high quality diagnostics and therapeutic solutions which they otherwise would not have had.¹⁵¹

COCIR¹⁵² provide some information as to the cost differences, explaining that refurbished medical systems on average are sold at a 30% lower price as compared to a comparable new system. COCIR further estimate the total difference in cost between refurbished MRI and new MRI sold in the EU annually would be from €4 to 8.5 million.

In an assessment done in 2012 of impacts of Article 2(2) on various product groups, BIOIS wrote that *“The resale value of the older equipment that will be replaced is typically ~10% of the cost of new EEE and hospitals rely on this money for their new equipment budgets.”*¹⁵³

¹⁵⁰ Op. cit EDMA/EUCOMED (2014a)

¹⁵¹ Op. cit. Medical Sector (2014)

¹⁵² Op. cit. COCIR (2014b)

¹⁵³ BIOIS & ERA Technology (2012), Measures to be implemented and additional impact assessment with regard to scope changes, pursuant to the new RoHS Directive – Final Report. Retrieved from: http://rohs.biois.com/documents/RoHS_II_IA_Final_Report.pdf

4.7.1 RoHS Compliance

It is understood from stakeholders that the main concern of compliance of refurbished devices and parts with RoHS regards compliance with the substance restrictions. It is subsequently understood that there are two main aspects that need to be clarified to establish the compliance of refurbished devices and/or parts with RoHS. The first aspect concerns the possible **presence of RoHS substances** within refurbished devices and/or parts. The second aspect concerns the respective **documentation of compliance** with the RoHS restrictions.

Potential for Presence of RoHS Substances

Here it is important to make a distinction between two groups:

- RoHS substances that are present in applications for which an exemption is listed in Annex III or IV and valid at the time the device or part is placed on the EU market. For such applications, compliance is achieved in light of the existence of an exemption and the product can be CE-marked. Since the product is compliant when first placed on the market, it can be refurbished and resold without needing to re-comply when re-sold on the market. As explained in Section 4.4.1, refurbished spare-parts have certain limitations in this regard when used in the assembly of new devices or when used to service devices first placed on external markets that are to be made available on the EU market for the first time.
- RoHS substances that are present in applications for which no exemption is available and for which substitutes are already used in new devices and parts. This is understood to be a main focus for this review, as the presence of RoHS substances in these cases is not supported by the Directive and its annexes, making the product non-compliant (i.e. the product is not permitted to be CE-marked).

Identifying applications in which RoHS substances have been phased out over the last 10 years can provide a good basis for understanding where such substances are to be expected, in light of the long time that devices and parts remain in circulation through refurbishment. In 2006, an ERA¹⁵⁴ study prepared for the EU Commission detailed applications in which RoHS substances are used in medical devices, also estimating the respective quantities to be placed on the market per annum. A summary of such applications is provided in Table 4-2 below:

¹⁵⁴ Goodman (2006) Goodman, P., Review of Directive 2002/95/EC (RoHS) categories 8 and 9 – Final Report. ERA Report 2006-0383, July 2006, amended September 2006, http://ec.europa.eu/environment/waste/pdf/era_study_final_report.pdf

Table 4-2: Weight of RoHS Restricted Substances Used in Category 8 Equipment, Including Data for Sub-categories Where Known

| Substance/ uses | Subcategory | | | | | Category 8 totals |
|---|---------------|---------------|--------------|-------|---------------------------|-------------------|
| | Radio-therapy | Nuclear (PET) | Lab in-vitro | AIMDs | Others types of equipment | |
| Lead shielding | 43,000 | 110,000 | | | 605,700 | 758,700 |
| Lead counterweight | 9,600 | 28,000 | | | 286,000 | 323,600 |
| Lead in MCP & CP | | | | | 1 | |
| Lead X-ray tube bearings | | | | | 1 | |
| Lead in X-ray test objects | | | | | 100 | |
| Lead in superconducting connections (MRI) | | | | | 6,000 | |
| Lead in superconducting connections SQUID detectors | | | | | < 0.1 | |
| Lead in refrigerator cold head | | | | | 100 | |
| Lead in ceramics (ultrasonic transducers) | | | | | 80 | |
| Lead in single crystal ultrasonic transducers | | | | | 100 - 200 | |
| Lead in lead stearate X-ray diffraction crystals for X-ray spectroscopy | | | | | < 0.001 | |
| Lead in solder to transducers | | | | | 6 | |
| Lead anode in oxygen sensors | | | | | 50 | |
| Lead in solder | | | 6,000 | 800 | | 66,000 |
| Lead PVC stabilisers | | | | | 500 | |
| Lead in alloys | | | 3,000 | | | |
| Lead in electrode glass | | | 70 | | | |
| Cadmium plating | | | | | 0.5 | |
| Cadmium in switches and contacts | | | | | | |
| Cadmium in phosphors | | | | | 13 - 103 | |
| Cadmium tungstate | | | | | 630 | |
| Cadmium semiconductor radiation detectors | | | | | 300 (of Cd) | |
| Cadmium in superconducting alloys | | | | | 600 | |
| Copper - cadmium wire | | | | | 50 | |
| Cadmium pigments | | | | | 5 | |
| Cadmium stabilisers in cables | | | | | | Should be zero |
| Hex Cr in alkali dispensers | | | | | 1 | |
| Hex Cr passivation | | | | | | 7 |
| Mercury in position switches | | | | | 1 | |
| Mercury in backlights & other lamps | | | | | | 0.7 |
| Mercury in electrodes | | | 2 - 10 | | | |

Source: Goodman (2006)

Regarding this data, the ERA¹⁵⁵ study further explains that the quantities are constantly changing. For example, new restrictions in the USA have resulted in significant reductions in the quantity of mercury used in electric products in the EU as early as 2004, so data for earlier years is already out of date. Many manufacturers

¹⁵⁵ Op. cit. Goodman (2006)

are already using lead-free solders in new models, although not changing designs. This will result in a decrease in the quantity of lead used in Cat. 8 and Cat. 9 products in future years. At the time of the study, EDMA estimated 6 tonnes of lead to be in use in solders in in-vitro diagnostics equipment, with this number expected to decrease to 600 kg regardless of the inclusion of Cat. 8 in RoHS.

It is understood that the medical sector was already working on compliance with RoHS in 2009, requiring possible substitute candidates to be tested and recertified for use in medical devices. As six years have gone by, it can be assumed that at least in some areas further substitutes have been developed and are currently implemented in the manufacture of new products. Nonetheless, RoHS substances are still expected to be present in such applications where devices and parts are refurbished. This is tied to the relatively long planned lifetime of such products. Thus, it is expected that refurbished devices and parts, where RoHS substances are used in applications for which no exemption is in place, could still be circulated for many years if this were to be permitted by the RoHS Directive.

Stakeholders have provided some estimations as to where Annex II substances are currently (December 2014) expected to be found in refurbished medical devices, and for how long they may continue to be found:

- EDMA/Eucomed¹⁵⁶ assume that for the parts that are not compliant [i.e., no exemptions in place for RoHS substance use], the ROHS restricted substances, most likely to be present, are Pb and CrVI. A safe assumption would be that all material could be in circulation until retirement for all affected platforms. Further information was thus provided stating that *“the average lifetime for a new IVD or larger medical equipment is 7 – 15 years. When a device is refurbished, not all parts are replaced. Those that are replaced can be replaced with new parts or recovered used parts. The new parts will be RoHS compliant (at the latest by July 2014/2016 respectively for MD and IVD). But the used parts could be non-compliant. The used parts could remain in the refurbished device another 7-15 years. Regardless of how long a part or instrument could last if repeatedly repaired or refurbished, the use of all platform related material ceases with the platform retirement date.”*
- Participants of the targeted stakeholder meeting¹⁵⁷ mentioned that typical RoHS substances are expected in parts of refurbished devices: lead in PCBs, lead in solders; substances in plastics. An OEM refurbisher of imaging devices estimated that for 2014 the average manufacture year of devices entering the refurbished pool is 2005 – devices may be circulated as refurbished devices for 10 years on average and parts probably for longer. Participants agreed that a transition period of 10-15 years may be needed for medical devices and electron microscopes, where parts are robust and have a long planned service life and thus could re-main in circulation for 10-20 years if refurbishment practices are not limited. This period is the average time needed from when a

¹⁵⁶ Op. cit EDMA/EUCOMED (2014a)

¹⁵⁷ Op. cit. Medical Sector (2014)

substance is phased-out of a specific part and until when it is no longer expected to be present in refurbished parts/devices.

- In COCIR's original request application¹⁵⁸ (which resulted in Ex. 31 of Annex IV), a few interesting examples were given:
- *“Many other parts from medical devices are refurbished and then used as spare parts. These include MRI coils, PCBs from many types of equipment, ultrasound transducers, monitors, grids, collimators, etc. Some of these will contain small amounts of lead, cadmium and hexavalent chromium although mercury, PBB and PBDE are unlikely to be present.”*
 - *“X-ray tube assemblies have to be periodically replaced and so the X-ray tubes with their housing assemblies are returned to the manufacturer who re-uses as many of the constituent parts as possible including the housings, to make new X-ray tube assemblies. New assemblies built from re-used parts are used as replacements for existing X-ray systems and also to construct new systems. Typically, the parts from an X-ray assembly housing can be re-used on average at least five times and as each has an average lifetime of 5 years, they are used for on average at least 25 years before recycling of materials. This period would be very much reduced if RoHS substance restrictions prevented re-use.”*

It is thus important to note that in some cases, refurbished parts can also be used in the assembly of new devices. Regarding X-ray tube assemblies, it is further mentioned that they may contain Pb, in aluminium/brass/steel alloys which may be used for housing and other parts, as well as in Pb sheet used for radiation shielding. Cr VI may be present in passivation coatings used for small inserts of the housing. COCIR also mention that all medical equipment manufacturers intended to stop using this Cr VI passivation coating processes before 2014.

Difficulties Concerning Documentation of Compliance

Regardless of the actual presence of RoHS substances, stakeholders have explained that one of the problems with actual compliance is tied to the requirement to provide sufficient documentation in declarations of conformity. In their contribution to the stakeholder consultation of Ex. Re. 2013-6, COCIR¹⁵⁹ explain that it is usually

¹⁵⁸ COCIR (2011), Application for new exemption, submitted 29.9.2011, available under: http://rohs.exemptions.oeko.info/fileadmin/user_upload/RoHS_VI/Request_2/COCIR_-_Exemption_request2_-_X_ray_and_other_parts_reuse.pdf

¹⁵⁹ COCIR (2014a), Contribution to RoHS Stakeholder Consultation of Ex. 2013-6, submitted 5.2.2014, available under: http://rohs.exemptions.oeko.info/fileadmin/user_upload/ROHS_Pack5/Request_2013-6/20140205_COCIR_Contribution_to_RoHS_stakeholder_consultation_5Feb2014.pdf

impossible to determine whether used parts contain RoHS restricted substances as the example for reuse of used MRI magnets demonstrates:

- Complete Bills of Materials (BOM) are available for MRI magnet types. However a significant percentage of original piece part suppliers no longer exist to obtain RoHS compliance certification.
- The original piece part components for the MRI magnet types are no longer available for Laboratory Testing/Analysis to determine RoHS compliance. Components have been obsoleted by supplier and are not carried in inventory.
- Magnet tear down for each of the magnet types could be performed to retrieve suspect piece part components for Laboratory Testing/Analysis. But magnet tear downs will violate the ASME/PED/AD2000 Pressure Vessel certification and essentially mean that the magnets will become unusable scrap suitable only for waste disposal. Also, a significant sample of each magnet type will often have to be torn down to accurately verify full compliance.
- Based on the unavailability of original component suppliers, piece part inventory and the invalidation of the magnet Pressure Vessel Certification, MRI Magnet RoHS Compliance assessment is not possible.

Participants of the targeted stakeholder meeting¹⁶⁰ also mentioned that some RoHS substances are not expected to be present; however there is a difficulty in obtaining documentation to prove this, especially for older products. For mercury this was said to be less of a problem as California, USA regulations from 2006 have restricted the use of Hg in medical devices, resulting in good documentation of use since 2006 and possibly also in a lower likelihood for this substance to be present in refurbished devices and parts. Documentation is thus also understood to be less of a problem for new products and parts than for old – an aspect that should be considered in relation to the ease of documentation, should new substances be restricted.

Regardless of the actual presence of RoHS substances, it can be followed that where proper documentation is not available, devices (or parts) could be rendered non-compliant in light of failure to establish a suitable declaration of conformity.

4.8 Results from the Public Consultation

A public consultation was not held for this review in light of the short period provided for the review. Information was collected through direct correspondence and through the targeted stakeholder meeting. Among others, information was provided by COCIR, EDMA/EUCOMED, Siemens Healthcare, PHILIPS Healthcare and FEI. Furthermore, documents and data collected in the past through the evaluations of the two earlier requests were also used a source of information.

4.9 Analysis of Impacts

The baseline of this assessment is the RoHS Directive which entered into force on 21.7.2011, before the addition of Ex. 31 to Annex IV, according to which, only some

¹⁶⁰ Op. cit. Medical Sector (2014)

refurbished articles could be made available on the EU market without needing to re-comply with the Article 4(1) substance restrictions. Analysis of impacts shall only regard the differences between this Baseline scenario (Option 1) and between the Exemption 31 scenario (Option 2) and the Exclusion 4(7) scenario (Option 3). Furthermore, estimations shall refer to refurbished medical devices and parts, that will need to re-comply with the RoHS substance restrictions at the time resold on the EU market, as such articles are understood to be the source for possible impacts in the various scenarios.

4.9.1 Impact Indicators

To clarify if an exclusion from the scope of RoHS or if exemptions would be justified on the basis of expected impacts, the analysis of the three options, must demonstrate that the benefits expected from the implementation of each scenario would be similar or larger than possible costs therefor. The overarching objective of the Directive is to contribute *“to the protection of human health and the environment...”*. This would require that costs and benefits relevant for the environment, for the economy and for society would be reviewed. On this basis, the impact indicators shown in Table 4-3 have been chosen as relevant in this context.

Table 4-3: Impact Indicators for the Refurbished Medical Devices and Parts

| Environmental indicators | Economic indicators | Social indicators |
|---|---|---|
| Impacts tied to use of RoHS substances | Impacts on manufacturers of new devices | Impacts on employment of manufacturers of new devices |
| Impacts tied to emissions of RoHS substances (focus on end-of-life) | Impacts on operators of refurbishment facilities | Impacts on employment of refurbishers of new devices |
| Impacts tied to use of Renewable and non-renewable resources | Possible distortions of internal market – focus on differences in impacts on OEM refurbishment and 3rd party refurbishment | Impacts on employment at medical facilities |
| Impacts on energy consumption | Possible changes to market structure (including wider impact on trade with non-EU countries) – mainly shift from global to regional refurbishment logistics | Impacts on health of patients (consumers of medical services) |
| | Administration costs for public authorities (market surveillance, health service budgets, RoHS exemptions) | Impacts on health of patients |
| | Impacts on consumers (medical service facilities) shift away from refurbished devices – impacts on product portfolio (age, diversity and range of services) and budget. | |

4.9.2 Environmental Impacts

It is understood that new medical devices are by now compliant with the RoHS substance restrictions, either through the use of substitutes for RoHS substances used in the past **or** through exemptions existing in Annexes III and IV, allowing further use of RoHS substances where substitution is not yet possible. With time it is expected that substitutes shall become available for additional applications and that some of the exemptions used today for establishing compliance shall become invalid. That said, it should be noted that it is unclear how fast this process is to phase out further RoHS substances in light of the small amount of RoHS substances that have been removed from new devices. COCIR¹⁶¹ have pointed out results of an analysis which show that RoHS by now only achieved removal of < 5% by weight of the content of the six substances, and that the remaining 95% is still present in light of existing exemptions (mainly lead for radiation protection).

As explained above, it is understood that only certain refurbished items are expected to have a problem with compliance. This regards:

- Refurbished devices first placed on an external market, which are to be made available on the EU market;
- Refurbished parts first placed on an external market, which are to be made available on the EU market (economic transaction, i.e., sale of spare parts to repair operations and/or to 3rd party refurbishers);
- Refurbished parts first placed on an EU market, which are to be used for assembling new devices or for repair of refurbished devices first placed on external markets which would otherwise comply with the RoHS substance restrictions at time of re-sale.

In such items, phase-out is expected to occur in applications for which substitution has been implemented in new devices and parts, however as these items may remain in circulation for an average of 10 to 15 years (with some circulating even longer), this phase-out shall be delayed in relation to the phase out in new items.

Furthermore, as progress of phase-out in new items is said at present to be developing slowly in the medical sector, related environmental benefits would be expected to occur slowly and over a long period of time. As mentioned in Section 4.7.1, the average time needed from when a substance is phased-out of a specific part and until when it is no longer expected to be present in refurbished medical parts/devices could be 10-15 years in light of the robustness and long-life of products. In the past, the ERA study¹⁶² had estimated that 21,000-46,000 tonnes of medical devices are placed on the EU market per year, estimating the following quantities of RoHS substances are thus placed on the market: 1060 tonnes of Pb; 1.8 tonnes Cd; 12 kg Hg; less than 0.3-0.8 tonnes of Cr VI (estimated for both Cat.

¹⁶¹ Op. cit. Medical Sector (2014)

¹⁶² See Presentation of study under http://ec.europa.eu/environment/waste/weee/pdf/era_presentation.pdf

and Cat. 9) and less than 10 tonnes of PBB and PBDE (estimated for both Cat. and Cat. 9).

If indeed replacements have been implemented for < 5 % (weight) of RoHS substances used in the past, the average time that a medical device may remain in service when refurbished and resold would be a basis for understanding the expected phase-out of these substances from medical devices. Based on the estimations of stakeholders that devices remain in service between 10-15 years, when refurbishment allows fulfilling the planned lifetime, the following amounts of RoHS substances could phase out of refurbished items over a period of 10-15 years if such items are not limited in terms of secondary market operations: 53 tonnes of Pb; 0.09 tonnes Cd; 0.6 kg Hg; less than 0.015-0.04 tonnes of Cr VI and less than 0.5 tonnes of PBB and PBDE.

If secondary market operations of refurbished items with compliance problems are to be limited, as in Option 1, the respective amounts of RoHS substances would be removed from the EU market immediately. In some cases devices and parts could be recirculated as this is allowed where the device was first placed on the EU market. Thus the amounts to be phased-out are expected to be smaller than the above numbers. However in parallel, for some devices this would either result in a shift of RoHS substances from the EU market to external markets (export of non-compliant refurbished items) or in products being scrapped earlier. If new devices would need to be manufactured to partially replace refurbished ones in medical facilities, this would further mean that additional resources and energy would need to be consumed.

In the following areas, impacts as a result of the three policy options are shortly discussed:

- **Impacts tied to use of RoHS substances:** The use of substances in refurbished devices and parts is related to the use at the time the product was manufactured. This use cannot be avoided regardless of which refurbished parts can circulate on the EU market and which cannot. In parallel, where refurbished items cannot be circulated and need to be removed (exported or sent to waste), this will result in the manufacture of new devices and parts to replace refurbished ones. As long as exemptions are still available in the annexes, the use of RoHS substances in such manufacture will also be unavoidable, even if the amounts shall slowly decrease over time where effective substitutes become available.
- **Impacts tied to emissions of RoHS substances (focus on end-of-life):** As the use of RoHS substances in manufacture shall not change in refurbished items, emissions associated with manufacture shall remain the same in all scenarios. Emissions associated with the other life-cycle phases could be distributed differently in time (if articles reach end-of-life early this could reduce emissions during use as the use phase is shortened, while emissions at end-of-life shall occur earlier) or they could be distributed differently geographically (if articles are exported, possible emissions shall occur elsewhere, with the range of end-of-life emissions depending on the nature of treatment [whether recycling or disposal] as well as on the quality of facilities; emissions in some cases may be expected to increase). Substances to be used in manufacture of replacement devices and parts shall exhibit emissions similarly, as new

substitutes become available, creating problems with items when they reach the refurbishment phase in cases where exemptions have expired. Nonetheless, impacts shall be small, in light of the slow phase-out pace of RoHS substances from Cat. 8.

- **Impacts on renewable and non-renewable resources:** Restriction of secondary market operations of refurbished items could result in early end-of-life of such items or in their export. The BIOIS¹⁶³ assessment explains “*One stakeholder has pointed out the large quantity of uncommon strategic materials that are in medical equipment. If refurbished equipment could not be re-used in the EU after July 2019, it will either be exported to users outside the EU or be recycled. There is an incentive that the equipment reaches its end-of-life in the EU so that it is recycled in the EU. The large weight of medical equipment such as MRI, CT and X-ray systems is a disincentive to export it outside the EU for recycling. A study by one manufacturer has shown that 94% of the weight of medical equipment can be either recycled (64%) or refurbished for second users (30%) so only 6% is land-filled. Another study found that large quantities of scarce materials are used and for one EU-based manufacturer in one year, this includes: 9 tonnes of niobium titanium superconductor, 61 tonnes copper, 57 tonnes stainless steel, 254 tonnes of aluminium alloys and 41 tonnes of neodymium iron boron magnets.*” Though the successful recycling of materials can be seen as a benefit, this benefit is one that would occur anyway at end-of-life, and possibly with a larger range, as recycling processes develop. Nonetheless such differences in impacts would probably be very small and possibly negligible. Thus the different distribution of environmental benefits over time is not necessarily a net benefit as potential for benefits in the future is the same or larger. If items are exported, this would result in a geographical shift of impacts, including impacts related to end-of-life, such as those connected to recyclable materials (though also those connected to emissions mentioned above). In parallel, manufacture of new devices to replace refurbished ones shall use a large amount of resources which would otherwise be used at a later time. As this process would mean that the same resources needed for manufacture remain in use for a shorter period, it is to be understood as a negative impact in terms of resource use and probably a significant one in light of the weight of refurbished medical devices such as imaging devices.
- **Impacts on energy consumption** – COCIR¹⁶⁴ claim that “*the refurbishment of medical equipment saves energy and resources by extending the lifetime of products that would otherwise be substituted with new ones. COCIR estimated that around 30 MWh can be saved for each ton of refurbished medical equipment, further specifying that between 2010 and 2012 more than 3600 tons of CT and MRI were refurbished (waste reduction) accounting for a saving of 97 GWh of energy*”. The report does not explain how these sums were

¹⁶³ Op. cit. BIOIS 2012)

¹⁶⁴ Op. cit. COCIR (2014b)

calculated. However, it can be followed that extension of the lifetime of a product will mean that energy consumption tied to manufacture and recycling is related to a longer product life, assumed as a significant benefit. In contrast new devices may be more efficient in terms of use of energy during the use-phase of the equipment, in comparison with older ones, casting a shadow upon benefits related to the other life-cycle phases. Thus benefits related to longer circulation of refurbished products are expected but their significance could differ due to the difference in energy consumption of devices of different ages.

To conclude, in terms of environmental impacts, both policy options 2 and 3, in which refurbished terms enjoy unlimited circulation on the EU market, show benefits in relation with Option 1.

4.9.3 Economic Impacts

As explained in the previous sections, restrictions to the circulation of refurbished products shall only apply to certain types of equipment. However, depending on the range of devices and parts that are denied EU market access this may have significant impacts related to the decrease in refurbishment operations, probably leading to loss of business and in some cases to close of certain facilities.

The various economic impact indicators have been analysed against this background:

- **Impacts on manufacturers of new devices:** Where new devices need to be manufactured to replace refurbished ones, manufacturers could increase volume of production, leading to benefits. The range of such benefits would depend on the range of refurbished devices affected, with the worst case being that refurbishment operations need to close if compliant activity does not justify such facilities from an economic perspective. Changes to the circulation of refurbished products shall not affect the use of RoHS substances directly, as it shall not impact the progress of finding and using substitutes in exempted applications (i.e. R&D also not expected to be affected). However if a significant amount of devices cannot be refurbished, such devices may reach end-of-life early (or be exported) requiring increased manufacture of replacement devices and parts. In this respect, impacts of limited refurbishment on the manufacture of new devices are expected to be positive differing in range according to how many devices are replaced and after what part of their planned lifetime.
- **Impacts on operators of refurbishment facilities:** On the background of the explanations provided above, it can be estimated that refurbishers (both 3rd party and OEMs¹⁶⁵) could have significant costs related to loss of business and in some cases closing of facilities. Once phase-out of RoHS substitutes stabilizes (available exemptions remain unchanged), the range of such costs shall decrease until either phase-out is completed in refurbished devices or

¹⁶⁵ It should be noted here that OEM refurbishment is usually run as a separate business.

new substance restrictions are added to Annex II, meaning that the phase-out process begins anew for certain products.

- **Possible distortions of internal market (focus on differences in impacts on OEM refurbishment and 3rd party refurbishment):** Though OEM refurbishers and 3rd party refurbishers are assumed to have the same restrictions to circulation of refurbished items, these could affect 3rd party refurbishers more heavily, as OEM refurbishers shall have easier access to information regarding the documentation of RoHS compliance. As time goes by, OEM refurbishers shall improve in terms of available information concerning presence of RoHS substances, as use of RoHS substances in newer devices is already documented more carefully. In contrast, 3rd party refurbishers are expected to have similar problems in access to information, which is often considered at least in part proprietary.
- **Possible changes to market structure (including wider impact on trade with non-EU countries):** If circulation of refurbished devices is to be limited, this shall mainly affect the possibility:
 - of using refurbished parts for repairing devices to be re-sold on the EU market first placed on external markets;
 - of using refurbished parts for assembly of new devices (placed on the market after category needs to comply with substance restrictions; and
 - of reselling refurbished devices on the EU, which were first placed on external markets.

Such refurbished items shall be denied access to the EU market but could still be exported for use in external markets. This is expected to lead to a surplus of refurbished items in external markets (possibly lowering their prices on such markets at the risk of economic feasibility of refurbishers), parallel to a lack of sufficient supply in the EU, which is currently a key market for such items (subsequently resulting in additional impacts on consumers / health service facilities / public health etc., as detailed below). This may also require logistic changes to the structure of refurbishment operations, either in tracking and distributing refurbished items or in creating separate facilities to avoid “contamination” between RoHS compliant and non-compliant devices and parts. One could argue that this may stimulate an EU specific refurbishment business, however it is difficult to say if this would result in a net benefit or not. Though additional operations could have a positive impact on employment, the establishment of such facilities shall also require investments and decreasing the scale of facilities may also have a negative impact on economic feasibility. Furthermore, stakeholders (COCIR 2014b) estimate that between 30-50% of refurbished devices sold in the EU were initially sold outside the EU. It is thus understood that a separation is likely to result in insufficient supply of refurbished articles in the EU market as well as a surplus in non-EU markets where the sale of refurbished devices is not yet as developed.

- **Administration costs:** Administration costs for public authorities are expected to be significant where market surveillance needs to enforce restrictions on refurbished items (limited market access) as well as to check compliance of

refurbished items with exemptions that could change from time to time. Costs are also expected where exemptions need to be reviewed for renewal from time to time, in light of the involvement of Member States in the process of granting exemptions. Where exemptions create administration costs, such costs would be expected to be lower, assuming that an exemption is aligned for all product groups regarding duration, since exemptions then only need to be reviewed every seven years, whereas market surveillance of restricted items is constant. Administration costs for industry are expected in terms of costs for maintaining documentation of compliance with substance restrictions (where substances with lacking documentation are not exempted/excluded for use) as well as costs for dealing with exemption requests where this is relevant.

- **Impacts on consumers:** Here impacts are mainly expected in terms of possible changes to product portfolio, i.e. changes in availability of devices and services in use. Such impacts shall be a consequence of a limited budget for purchasing medical devices, which shall be burdened more heavily if only new devices are available (or a limited variety of refurbished ones).

To conclude, in terms of economic impacts, both policy options 2 and 3, in which refurbished terms enjoy unlimited circulation on the EU market, show benefits in relation with Option 1. Though manufacturers may have a small positive impact in Option 1 where the limitations to the circulation of refurbished products creates an increase in manufacture of new devices, for all other indicators, benefits are expected to be higher in both Options 2 and 3.

4.9.4 Social Impacts

Concerning social impacts, it is assumed that both impacts on employment and impacts on consumers would be sensitive to limitations on secondary market operations of refurbished items on the EU market.

The social indicators are thus analysed as follows:

- **Impacts on employment:** With regards to employment it is worth noting that COCIR¹⁶⁶ explain that “*most category 8 and 9 manufacturers have only one refurbishment centre for each type of product...*”. It is also understood that manufacture (including assembly of supplied parts) of a certain device or of certain models shall also be performed at a single location. It should further be kept in mind that refurbishment operations of OEMs are often managed as a separate business, with 3rd party refurbishers also depending on the ability to refurbish devices. If refurbishment activities are to decrease, this may have a negative impact on employment, with its range depending on how many refurbished items are denied access to the EU market. One could argue that limited access to the EU for refurbished items would mean that more items are

¹⁶⁶ Op. cit. COCIR (2014a)

available for refurbishment and sale in non-EU countries, causing an increase in employment opportunities outside the EU. However to begin with, the location of operations is not limited by RoHS, which only limits the sales, and facilities would not necessarily be expected to move to other countries. Though the origin and the destiny of devices may influence the location of a facility, it is understood that both transaction types shall in any case be distributed over the world and would not necessarily change enough to impact location, if Option 1 were to limit the resale of refurbished items. In contrast it has been communicated by a key manufacturer of imaging devices that the location of suppliers and manufacturers of components can be of relevance to locating a refurbishment facility¹⁶⁷. As these are not expected to change in the various options, the main impact on employment is expected to be related to the volume of refurbishment. Since at present, the EU is the most significant market for refurbished equipment (39%), limiting sale of such equipment to this market could flood external markets with refurbished items, possibly resulting in a decrease in market prices. If prices are to go down significantly, this would have an impact on feasibility of refurbishment operations from an economic point of view possibly leading to the closing of some of facilities. Impacts on employment in facilities manufacturing new devices shall either be non-existent (no change to the range of refurbishment) or small (manufacture of new devices to replace refurbished ones). As for impacts on employment at medical facilities, restrictions on the circulation of refurbished devices shall raise costs for facilities in light of the limited supply of refurbished (and cheaper) devices on the EU market. In some facilities, this will result in the use of older devices and in some in the provision of fewer devices, i.e., fewer services. It is difficult to say how this would impact employment in the medical sector. Fewer devices could mean less employment for servicing devices (e.g. medical imaging technicians). However, if this is to have medical impacts on patients in light of larger waiting times or impacts on the exactness of diagnostics, this could also create additional employment for administration and/or nursing. As newer devices may be more automated, the longer use of older devices may also require more servicing employees in some cases.

- **Impacts on health of patients (consumers of medical services)** – BIOIS¹⁶⁸ explain that *“The result of including category 8 in scope of RoHS is that there would be less refurbished equipment available after 21 July 2014 because of hospital’s budgetary constraint that prevents them from buying more expensive new equipment. Many hospitals that would have bought a refurbished system will either have to wait longer to acquire one until one originally placed on the EU market becomes available or they will have to buy new instead. This could either prevent purchase of other equipment or delay*

¹⁶⁷ It was explained that during refurbishment, some operations would be carried out by the original supplier, for example aesthetic „touch-ups” of casings. As equipment can be heavy, location of suppliers and manufacturers of components can be an important factor in locating a refurbishment facility.

¹⁶⁸ Op. cit. BIOIS (2012)

purchase of equipment until sufficient funds are available for a new unit. Overall, this will result in the average age of medical equipment becoming older as equipment replacement is delayed. It is known that the performance of old equipment for diagnosis accuracy and treatment success is inferior to newer machines although it is not possible to quantify this as there are many variables that influence medical treatment. Old equipment also tends to be less reliable and so there will be delays to treatment when breakdowns occur and this can have serious implications.” This can be followed, and it is thus concluded that patients shall likely have negative impacts where access to health services decrease, though it is difficult to estimate the range of such effects. A negligible to small impact is assumed to be a conservative estimation.

To conclude, in terms of social impacts, both policy Options 2 and 3, in which refurbished items enjoy unlimited circulation on the EU market, are expected to have benefits in relation with Option 1.

4.10 Summarised Comparison of Options

The results of the assessment of the various identified indicators relevant to environmental, economic and social impacts are summarised in Table 4-4.

Table 4-4: Comparison of Options – Range of Impacts in Relation to Option 1 (Business as Usual)

| Impact indicators | Option 1: Business as usual – certain refurbished items denied market access | Option 2: Exemption 31 – refurbished items can be circulated | Option 3: Exclusion 4(7) - refurbished items can be circulated |
|---|---|---|---|
| Environmental Indicators | | | |
| Impacts tied to use of RoHS substances | = | + | + |
| Impacts tied to emissions of RoHS substances (focus on end-of-life) | = | + | + |
| Impacts tied to use of Renewable and non-renewable resources | = | ++ | ++ |
| Impacts on energy consumption | = | =/+ | =/+ |
| Total Environmental Impacts | = | Between + and ++ | Between + and ++ |
| Economic Indicators | | | |
| Impacts on manufacturers of new devices | = | - | - |
| Impacts on operators of refurbishment facilities | = | ++ / +++ | ++ / +++ |
| Possible distortions of internal market | = | + / ++ | + / ++ |

| Impact indicators | | Option 1: Business as usual – certain refurbished items denied market access | Option 2: Exemption 31 – refurbished items can be circulated | Option 3: Exclusion 4(7) - refurbished items can be circulated |
|---|--|---|---|---|
| (focus on differences in impacts on OEM refurbishment and 3rd party refurbishment) | | | Impacts on 3 rd party refurbishers to increase with time in comparison with Option 1 | Impacts on 3 rd party refurbishers to increase with time in comparison with Option 1 |
| Possible changes to market structure (including wider impact on trade with non-EU countries) – mainly shift from global to regional refurbishment logistics | | = | ++ (impacts related to logistic changes of refurbishment operations) | ++ (impacts related to logistic changes of refurbishment operations) |
| Administration costs | Administration costs for public authorities (market surveillance, health service budgets, RoHS exemptions) | = | + | ++ |
| | Administration costs for industry | = | + | ++ |
| Impacts on consumers (medical service facilities) shift away from refurbished devices – impacts on product portfolio (age, diversity and range of services) and budget. | | = | + | + |
| Total Economic Impacts | | = | + | ++ |
| Social Indicators | | | | |
| Impacts on employment of manufacturers of new devices | | = | - | - |
| Impacts on employment of refurbishers of new devices | | = | + / ++ / +++ | + / ++ / +++ |
| Impacts on employment at medical facilities | | = | - / + | - / + |
| Impacts on health of patients (consumers of medical services) | | = | = / + | = / + |
| Total Social Impacts | | = | Between - and +++ | Between - and +++ |
| Annotation Used | | | | |
| +++ Substantial positive effect | | | | |
| ++ Positive effect | | | | |
| + Slight positive effect | | | | |
| = No effect | | | | |

| Impact indicators | Option 1: Business as usual – certain refurbished items denied market access | Option 2: Exemption 31 – refurbished items can be circulated | Option 3: Exclusion 4(7) - refurbished items can be circulated |
|-------------------|---|---|---|
| - | Slight negative effect | | |
| -- | Negative effect | | |
| --- | Substantial negative effect | | |
| ? | Unknown effect | | |

In relation to the overall policy objective of RoHS 2, namely “to contribute to the protection of human health and the environment, including the environmentally sound recovery and disposal of waste EEE”¹⁶⁹, the discussion above shows that including restriction of refurbished devices and parts by RoHS 2 are not expected to contribute to this objective. In general, the Business as Usual is only expected to have benefits in terms of impacts on manufacturers of new devices and parts as well as impacts related to employment at such facilities. The two other options show similar costs and benefits, with the Exclusion 4(7) Option, showing slightly higher benefits where administrative costs of regulation authorities and industry are concerned.

4.11 Recommendation

Based on this assessment, it is recommended to resolve issues of the medical sector through exclusion of refurbished devices and parts from the scope of the directive via a new Article 4(7) to incorporate the general intention of the current Ex. 31.

Although these issues could be resolved through exemptions, this would create uncertainty as well administrative costs for both public and private (commercial) administration without an expected difference in environmental impacts (i.e., additional environmental benefits) that could set-off such costs. In comparison, resolving these issues through an Article 4(7) exclusion would reduce such efforts and costs.

It should also be noted that Ex. 31 in its current formulation does not resolve the problems of the medical sector, as it refers to the market, which in the context of RoHS is the Union market. Thus the exemption does not allow for the resale of refurbished equipment in the EU market, which was not placed on the market before July 2014 for medical devices and before July 2016 for IVD medical devices. Furthermore, this exemption formulation only allows the presence of Pb, Cd and Cr VI in reused spare parts. This means that where documentation is lacking to prove that other RoHS substances are not present, resale on the EU market shall be forbidden as well. Though the formulation of this exemption is being discussed as a result of the evaluation of Ex. Re. 2013-6, it is not yet known if an amended formulation is to be granted, providing a temporary solution to bridge the time needed for approving an exclusion.

¹⁶⁹ 2011/65/EU, Article 1

Without a temporary solution (i.e. a time limited exemption) significant negative impacts could be expected to the various players, in light of the restrictions to apply to refurbished devices and parts until an amendment of Article 4 comes into force. For IVD devices, which shall only need to comply with the substance restrictions in July 2016, such impacts may be smaller in comparison with other medical devices in scope such as imaging devices. However, as long as there is uncertainty, as to if an exclusion is to be granted, this could affect the scale of existing refurbishment operations as well as the potential development of such operations for additional medical devices. As refurbishment operations are understood to provide environmental benefits in light of the extended use of devices, this would not be beneficial. The provision of a temporary exemption shall also allow learning as to the suitability of a specific wording formulation for exempting the existing operations for which it is meant. As the current experience with Ex. 31 already shows that arriving at the optimal wording formulation could be complicated and require time, this is also understood to have a benefit, both for industry and for regulators who need to enforce the exemption. The following wording which is being discussed as an amendment for Ex. 31 is recommended as a starting point, whereas it would also be recommended to discuss this formulation and its suitability again as part of the process of approving an exclusion:

| Exemption | Duration |
|--|--|
| Lead, cadmium, hexavalent chromium, polybrominated biphenyls (PBB) and polybrominated diphenyl ethers (PBDE) in spare parts recovered from and used for the repair or refurbishment of medical devices, including in vitro diagnostic medical devices, or electron microscopes and their accessories, provided that the reuse takes place in auditable closed-loop business-to-business return systems and that each reuse of parts is notified to the customer. | Expires on i. 21 July 2021 for the use in medical devices other than in-vitro diagnostic medical devices; ii. 21 July 2023 for the use in in-vitro diagnostic medical devices; iii. 21 July 2024 for the use in electron microscopes and their accessories. |

It should further be noted that the recommended solution may also be relevant for electron-microscopes, for which it has been confirmed that there are many similarities in the devices and the aspects of their refurbishment.

Though additional product groups may also be of relevance, information as to the existence of such operations has not been made available by stakeholders. Without an in depth review of such operations and the environmental, economic and social aspects related to their continuation, concluding as to the relevance of an exemption/exclusion from RoHS for such products would not be recommended.

4.12 References

- BIOIS & ERA (2012) BIOIS & ERA Technology (2012), Measures to be implemented and additional impact assessment with regard to scope changes, pursuant to the new RoHS Directive – Final Report. Retrieved from:
http://rohs.biois.com/documents/RoHS_II_IA_Final_Report.pdf
- COCIR et. al. (2009) COCIR, JIRA, MITA (2009), Green Paper on Good Refurbishment Practice (GRP) for Medical Imaging Equipment.
- COCIR (2011) COCIR (2011), Application for new exemption, Submitted 29.9.2011, available under:
[http://rohs.exemptions.oeko.info/fileadmin/user_upload/RoHS_VI/Request_2/COCIR - Exemption request2 - X ray and other parts reuse.pdf](http://rohs.exemptions.oeko.info/fileadmin/user_upload/RoHS_VI/Request_2/COCIR_-_Exemption_request2_-_X_ray_and_other_parts_reuse.pdf)
- COCIR (2014a) COCIR (2014a), Contribution to RoHS Stakeholder Consultation of Ex. 2013-6, submitted 5.2.2014, available under:
http://rohs.exemptions.oeko.info/fileadmin/user_upload/ROHS_Pack5/Request_2013-6/20140205_COCIR_Contribution_to_RoHS_stakeholder_consultation_5Feb_2014.pdf
- COCIR (2014b) COCIR (2014b), Impact Assessment of RoHS II on Refurbishment of Medical Equipment Affecting Industry, Environment and EU Patients – Summary, dated 29 April 2014
- EU Parliament (2011) European Parliament (2011) Directive 2011/65/EU under
<http://eur-lex.europa.eu/legal-content/EN/TXT/?uri=CELEX:32011L0065>
- EU COM (2012) European Commission (2012) , RoHS FAQ Document, last updated 12.12.2012, last accessed 10.12.2014, available under
http://ec.europa.eu/environment/waste/rohs_eee/pdf/faq.pdf
- Goodman (2006) Goodman, P. (2006), Review of Directive 2002/95/EC (RoHS) categories 8 and 9 – Final Report. ERA Report 2006-0383, July 2006, amended September 2006,
http://ec.europa.eu/environment/waste/pdf/era_study_final_report.pdf
- Medical Sector (2014) Medical Sector (2014) Protocol of Targeted Stakeholder Meeting concerning Medical refurbishment in the context of RoHS, held in Brussels, Belgium, on 27 November 2014

A.1.0 Appendix 1: Summary of Stakeholder Contributions Related to the Review of Non-Road Mobile Machinery (NRMM)

Table 4-5: Summary of Stakeholder Contributions Related to the Review of NRMM

| Supporting stakeholders | Products/ machines of relevance | Relevance to NRMM and Compliance with RoHS |
|---|---|---|
| EUnited Cleaning – European Cleaning Machines Association ¹⁷⁰ | Professional cleaning machines and appliances - for example sweepers, scrubber driers which are cord-connected. Same product with on board power source out of the scope. | Understood to fall under the definition of NRMM as machines are in movement between a succession of fixed working locations while working and exclusion would only be relevant to machinery made exclusively available for professional use, which have more stringent mechanical demands in comparison with similar devices designed for private consumers. RoHS substances may be present in very low concentrations in different electronic components such as printed circuit boards; switches; In-harmonic vibrations and strong mechanical demand of the machine make substitutions difficult. For example, RoHS compliant alternatives must meet these requirements, e.g., secure solder joints, despite the use of lead-free solders, reliable corrosion protection, despite absence of chromium(VI), safe electrical lines, despite phasing out of lead and cadmium. |
| CEMA - the European association representing the agricultural machinery industry ¹⁷¹ | Tractors and agricultural self-propelled machines; Agricultural trailers; truck trailers; interchangeable towed equipment; | <p>Tractors and agricultural self-propelled machines are excluded due to Article 2(4)(g).</p> <p>Agricultural trailers (category R) and interchangeable towed equipment (category S) are not excluded solely based on the definition provided for NRMM with the additional wording of ‘with an on-board power source’ (unless it is exempted by article 2 point 4 c) – <i>equipment which is specifically designed, and is to be installed, as part of another type of equipment that is excluded or does not fall within the scope of this Directive, which can fulfil its function only if it is part of that equipment, and which can be replaced only by the same specifically designed equipment</i>; - R&S vehicles are exclusively used with tractors. The only issue may be the wording ‘installation’ as it is rather coupled and decoupled, not installed).</p> <p>Concerning agricultural trailers: the truck trailers (category O) are excluded while agricultural trailers would not. It concerns a fraction of the truck trailers (ag. trailers have a total turnover of less than a Billion €). There is little electronics on such vehicles (braking...).</p> |

¹⁷⁰ EUnited Cleaning (2014b), EUnited Cleaning Answers to NRMM Questionnaire, submitted per email on 28.11.2014

¹⁷¹ CEMA (2014b), CEMA Answers to NRMM Questionnaire, submitted per email on 03.12.2014.

| | | |
|---|---|---|
| | | <p>Concerning interchangeable towed equipment: self-propelled versions like self-propelled sprayers, harvesters,... would be excluded but not the towed version. There are also interchangeable towed equipment that are unique in their functionalities.</p> <p>In addition there are many mounted implements that are coupled to the three point lift of the tractor, many have hardly electronics on board.</p> |
| <p>CECE – Committee for European Construction Equipment¹⁷²</p> | <p>Underground Coal Shuttle Cars (probably excluded); Underground Hard Rock Jumbo Drill (diesel engine drivetrain, but cable powered while drilling); Underground Rock Header; Rotary blast hole drills (diesel and electric trailing cable models exist); Underground Coal Roof bolters; Underground Coal Continuous Miners; Electric Rope Shovels; Draglines; Hydraulic Mining Shovels (external cable power source and on-board power source models); Hauling trucks equipped with trolley system – (probably excluded);</p> | <p>Several types of construction machinery are electric powered, and thus have cables that provide a power source, rather than an on-board engine. The provided example machines are electric powered non-road mobile machinery used primarily in mining that are practically identical to diesel powered (or gas powered) non-road mobile machinery in every other respect.</p> <p>Lead-free solder is significantly more brittle than leaded solder and therefore is less able to function in extreme conditions. More work is required to validate its use on construction and mining machines.</p> |
| <p>EUROMOT – The European Association of Internal Combustion Engine Manufacturers¹⁷³</p> | <p>Reciprocating engine models and families manufactured by most industry participants are applied across many end use applications. The same basic engine model may be used in gensets, earthmoving equipment and</p> | <p>EUROMOT explain that earthmoving equipment and marine engines are understood to be out of scope, however that it could be interpreted that certain machines characterised as ‘non-road mobile machinery’ in the engine exhaust emission legislation 97/68/EC are not considered to be NRMM under article 3(28) of 2011/65/EU. A non-exclusive example is mobile gensets, which can be found in sizes in excess of 2000 kW. A standard generator set may be trailer-mounted for mobile application, yet the same type of genset may be installed at a fixed location, comprising a large-scale fixed installation (excluded from scope as such). The latter are</p> |

¹⁷² CECE (2014a), CECE Answers to NRMM Questionnaire, submitted per email on 05.12.2014

¹⁷³ EUROMOT (2014b), EUROMOT Answers to NRMM Questionnaire, submitted per email on 2.12.2014

| | | |
|---|--|---|
| | marine engines. | EEE designed to be mobile and move between a succession of fixed working locations, but they operate at the locations, and not while they are being moved between locations and thus do not fall under the definition of NRMM. The main RoHS substance of concern is lead. Lead is present as an alloy element or thin layer in engine bearings and bushings. It is used in bearings and bushings for some components of complete engine packages including air compressors and starters. Lead is used in solder for electronic and electrical components as well as in radiators and other coolers. Of greatest concern is lead used in larger size main and connecting rod bearings where no effective substitute has yet been developed. Lead from all these components would typically comprise less than .025% of a complete engine. |
| NAM – National Association for Manufacturers ¹⁷⁴ | Mobile electrical generators; petroleum extraction equipment; industrial power systems | Mobile machinery with on-board power source, intended to be moved between multiple job-sites in the course of its useful life, however operative only when installed at a fix location. This aspect disqualifies such equipment from the LSFI exclusion, in light or equipment being moved from place to place (not exclusively fixed) and from the NRMM exclusion as equipment is not mobile while working. Main concern of non-compliance appears to be related to lead bearings, however input is not very detailed and so example may not be exhaustive. |
| EUROPGEN – the European Generation Set Association ¹⁷⁵ (Contribution also submitted by a manufacturer of diesel engines for a variety of applications and power generation equipment) | Assumed out of scope: Propulsion generators used in marine vessels; Engines in mining /construction equipment; Permanently installed power generation equipment (standby or continuous duty power ratings > 375 kW); Assumed in scope: Generator for non-permanent installation | Diesel engines are utilized in a broad array of end use applications due to their efficiency and re-liability. Because of the many marketable uses of diesel power, a single engine platform, identical in design and construction, is commonly used in multiple applications. However, these end use applications are regulated inconsistently. Typically lead is present in engine bearings, some electronic and cooling system components, and in some aluminium and copper alloys used in precision components such as housings, covers, connectors, and fittings. |

¹⁷⁴ NAM (2014a), NAM (2014a), NAM Answers to NRMM Questionnaire, submitted per email on 2.12.2014

¹⁷⁵ EUROPGEN (2014a), EUROPGEN Answers to NRMM Questionnaire, submitted per email on 2.12.2014

A.2.0 Appendix 2: Questionnaire Concerning Impacts on Refurbishment - Technical and Socio-economic Considerations Concerning Refurbishment Practices in the Context of RoHS

Questionnaire Concerning Impacts on Refurbishment

Technical and socio-economic considerations concerning refurbishment practices in the context of RoHS

Background

Directive 2011/65/EU (RoHS 2) restricts the use of certain hazardous substances in electrical and electronic equipment. The scope RoHS 2 is stipulated in Article 2 of the legal text, in short stating that the “*Directive shall... apply to EEE falling within the categories set out in Annex I.*”

Recently stakeholders have notified the European Commission (EU COM) that a number of problems were identified in this regard, which should be analysed in depth. The EU COM has thus launched a study with the purpose of assessing economic, social and environmental impacts of various scope related provisions as well as the need for clarifications or for a legal amendment in accordance with the Commission's right of legislative initiative.

Refurbishment operations in the medical sector have been identified in this regard. An important part of the EEE business is refurbishment. Expensive hi-tech equipment such as larger medical devices will rather be refurbished than recycled. According to new stakeholder input, the material flows in this sector have changed over the past few years. More and more refurbished (i.e. new) products are sold (placed on the market) in Europe, and more and more old ("non-compliant") products from outside Europe that had not been placed on the EU market before enter the refurbishment facilities in the EU.

Article 4(5) of the Directive exempts certain spare parts from the need to comply with the substance restriction: “*Paragraph 1 shall not apply to reused spare parts, recovered from EEE placed on the market before 1 July 2006 and used in equipment placed on the market before 1 July 2016, provided that reuse takes place in auditable closed-loop business-to-business return systems, and that the reuse of parts is notified to the consumer.*” Refurbishment practices are understood to be partially addressed in this article, though the dates of applicability would not allow for

the medical sector to benefit from this paragraph. None the less, this section was one of the Directive entries, supporting past interpretations that refurbishment practices were understood to be beneficial from an environmental perspective by the European Parliament at the time of the recasting of RoHS. This is further supported by Item 20 at the beginning of the legal text, stipulating “As product reuse, refurbishment and extension of lifetime are beneficial, spare parts need to be available”.

Though it can be understood from these articles that refurbishment is common practice in some sub-sectors of the EEE industry, recent inquiries made by representatives of categories 8 (medical devices) and 9 (monitoring and control instruments) suggest that such practices are at present implemented only for some product groups:

Refurbishment practices of the medical sector have been raised in the past in the context of requests for exemptions and have resulted in the addition of Exemption 31 in Annex IV of RoHS 2¹⁷⁶.

A further request was made by a manufacturer of electron microscopes (Sub-Cat. 9 industrial) in 2013, for which an evaluation completed in October 2010¹⁷⁷.

The Oeko-Institut has been appointed within a framework contract¹⁷⁸ to provide the European Commission with further input aimed at substantiating:

- the share of products affected;
- The categories (or sub-categories where these practices exist and where they are expected to develop;
- their manufacturers' (or refurbishment operator's) technical or procedural problems with RoHS compliance;
- where in the product and in the supply chain the problems can be located and tackled;
- what remedies might help solve such problems;

The objective of this questionnaire and the review process is to collect and to evaluate information and evidence relevant for establishing the various environmental, the economical and the social impacts that different policy options

¹⁷⁶ See Amendment under: <http://eur-lex.europa.eu/legal-content/EN/TXT/PDF/?uri=CELEX:32014L0015&from=EN>

¹⁷⁷ See final report under: http://rohs.exemptions.oeko.info/fileadmin/user_upload/ROHS_Pack5/201410_RoHS_Ex_Pack5_Final_Report_final.pdf

¹⁷⁸ Contract is implemented through Framework Contract No. ENV.C.2/FRA/2011/0020 led by Eunomia

may result in. Additionally, information clarifying the application of RoHS regulated substances (see Annex II of Directive 2011/65/EU¹⁷⁹) and the technical aspects of their substitution in this product category are also of interest.

The following questions have been formulated to gather more information on “*refurbishment practices*” which are understood to fall in the scope of the RoHS Directive, as well as information concerning the *refurbishment operators and their* supply chain and “consumers”, regarding possible impacts that they may have in relation with the RoHS Directive. Input provided in this regard shall be used to review if the impacts of possible scenarios for addressing such practices in the RoHS Directive.

We are thus approaching your organisation in request of information of relevance in this regard and shall appreciate if you could answer the following questions. Please be aware that some of the questions may refer to specific aspects or sub-product groups. Please clarify if certain aspects are of less relevance for your type of organisation/products.

Questions:

1. Scope of refurbishment practices

Please specify product groups of relevance for your organisation for which refurbishment practices exist. Please also refer to:

- i. The RoHS Annex I category of relevance;
- ii. Logistic aspects of refurbishing (i.e. do facilities refurbish and remarket products only within the EU or on a global scale);
- iii. The relevance of cases in which similar products are impacted differently by the Directive where refurbishment is concerned (i.e., with some products in scope and others of similar design excluded from scope or falling in different categories such as in the case of medical and veterinary devices);
- iv. Please estimate how long parts recovered from such products could continue to circulate through refurbishment practices in terms of expected functional service life;

¹⁷⁹ <http://eur-lex.europa.eu/LexUriServ/LexUriServ.do?uri=CELEX:32011L0065:EN:NOT>.

2. Market share of refurbished products

To allow quantification of impacts of various scenarios, it shall be important to understand the range of market share of refurbished products from the total sales relevant to a specific product group. In this respect:

- i. Please provide information as to the general sales volume of example product groups of relevance;
- ii. Please provide information as to the market shares of new products and refurbished products from the sales volumes mentioned above;
- iii. If possible please provide forecasted trends for the next 10 years;
- iv. Please indicate in your answers what information (or market share) is relevant for the EU and what is relevant for the global market;

3. Compliance of refurbished items with RoHS

The RoHS Directive restricts the use of certain hazardous substances in EEE that is to be marketed on the European market (2011/65/EU, Annex II). Annex II specifies maximum concentration values of the different hazardous materials that are tolerated by weight in homogeneous materials. Currently the following substances listed in Annex II are restricted above a maximum concentration values (%/weight): lead (0,1 %); mercury (0,1 %); cadmium (0,01 %); hexavalent chromium (0,1 %); polybrominated biphenyls (PBB) (0,1 %); polybrominated diphenyl ethers (PBDE) (0,1 %).

- i. Please specify what substances may be present above the maximum concentration levels specified in Annex II to the Directive in product groups for which refurbishment is practiced;
- ii. As refurbishment allows older products (or parts thereof) to remain in circulation, please estimate how long substances are expected to remain in circulation through refurbishment practices (i.e., once substitution is implemented in new products how long shall substances still be circulated);

4. Possible scenarios to address refurbishment under RoHS

As described above, at present refurbishment practices are addressed in part through Article 4(5) and in part through Annex IV Exemption 31. The following scenarios are under investigation as a means for addressing refurbishment practices under RoHS in the future:

- The **2011 scenario**: Refurbishment shall only be allowed in line with the current formulation of Article 4(5) – i.e. exemptions for refurbishment practices in products not covered under this article shall not be available;¹⁸⁰
 - The **exemption scenario**: Refurbishment to be covered through temporary exemptions that shall need to be renewed from time to time according to necessity for various product categories or product groups;
 - The **long-term scenario**: Refurbishment to be covered through an amendment of the RoHS legal text (for example through addition of a new item to Article 4), allowing refurbishment practices for certain product categories and/or product groups;
- i. Please indicate what scenario could cover the needs of products relevant for your organisation in terms of refurbishment;
 - ii. Please propose a formulation for the preferred scenario which covers aspects of importance for the refurbishment practice of your organisation (its members). Please clarify how various terms within this formulation are understood/defined (please also see questions regarding “Terms and Definitions of Importance in this regard);
 - iii. Please specify aspects of relevance in the respective refurbishment practices that could be incorporated into a possible scenario and explain their importance, for example:
 1. Relevance of product category or product group;
 2. Relevance of global operations and EU operations;
 3. Relevance of presence of RoHS substances / RoHS compliance (i.e., CE marking of products placed on the market in the past);
 4. Additional aspects;
 - iv. Please detail what consequences the various scenarios may have for your organisation (it’s members) in terms of:
 1. Economic impacts: costs and benefits among others for:
 - a. Manufacturers (including SMEs where relevant);
 - b. the supply chain(including SMEs where relevant);
 - c. impacts on competition (also concerning non-European manufactures);
 - d. impacts on consumers (commercial and/or private);
 2. Environmental impacts: among others costs and benefits related to:
 - a. Phase-out of RoHS substances;

¹⁸⁰ Please note that it is not anticipated that such a scenario be approved in light of the COM's decisions in this regard in the past, however the scenario is investigated as a base line for comparing costs and benefits related to other alternatives.

- b. Impacts on end-of-life
- 3. Social impacts:
 - a. Impacts on health;
 - b. Impacts on employment;
 - c. Impacts on consumers;

5. Terms and definitions of importance

How certain terms are understood by various players shall have an important role in how the formulation of an exemption or of an adaptation of the RoHS legal text is to be interpreted and applied by various stakeholders. In reviews related to refurbishment that have been performed in the context of the RoHS Directive so far, a number of terms have been identified, for which definitions are lacking or do not provide sufficient clarity for stakeholders as to what is covered by the term and what is not.

- i. Please detail how, or on the basis of what legal documents or standards, your organisation understands the following terms and what their relevance is to the possible scenarios for addressing refurbishment under RoHS:
 - 1. Spare parts;
 - 2. Components;
 - 3. Parts;
 - 4. Refurbishment;
 - 5. Placing/making available on the market (i.e., does market refer to EU market/global market, etc.)
- ii. Please propose additional terms of importance if this is relevant for addressing refurbishment activities for which the exemption (or exclusion) is being reviewed;

In case parts of your contribution are confidential, please clearly mark relevant text excerpts or provide your contribution in two versions (public /confidential).

Please be aware that input is preferred in writing in order to allow for referencing various views and for documentation reasons, however conducting a first telephone interview to clarify the areas of interest and the focus of information that your organisation may provide is possible.

If such an interview is relevant, please contact:

**Ms. Yifaat Baron – Project Manager - RoHS exemptions evaluation
rohs.exemptions@oeko.de and/or Phone: +49 761 45 295 - 266**